



Operator Guide

DSR-7400 HD Series

(DSR-7403, DSR-7406, and DSR-7412)

Firmware Version: 0x340eXX

Commercial Integrated Transcoder / Receiver

ARRIS DSR-7400 HD Series Operator Guide

Document Number	Firmware Version	Revision
365-095-33219	0x340eXX	x.6

Revision History

Revision	Date	Reason for Change
x.1	6/26/2018	This document adds the following features: Analog Output, Ethernet Input, and DVB-S2x, and DCII-QPSK modulation modes. The previously-published version of this document is 365-095-31961, Revision x.1.
x.2	11/2/2018	This document describes all features and capabilities associated with firmware version 0x300eXX. This document presents a new maximum temperature of 40° C [104° F], as shown on page 19.
x.3	03/22/2019	This document describes all features and capabilities associated with firmware version 0x310eXX. DSR-7406 information was added to this document. This document provides more-thorough information about configuring Keep Alive (see page 32), IP input, and IP output (see pages 81 to 85). The DSR-7412 complies to the VCI statement that is shown on page 107.
x.4	05/17/2019	This document describes all features and capabilities associated with firmware version 0x320eXX. This document lists the support for DVB subtitles (stated on pages 14) and includes the Spare Transcoders statement (shown at the bottom of this page).
x.5	10/22/2019	This document describes all features and capabilities associated with firmware version 0x324eXX.
x.6	07/27/2020	This document describes all features and capabilities associated with firmware version 0x340eXX. This document provides information about configuring a DigiCipher Streaming Service for program delivery through Internet CDNs (Content Distribution Networks).

Spare DSR-7400 HD Series Transcoders

As programmer services continue to transition to advanced modulation and updated compression formats; it's important to consider your backup options. ARRIS distributors have available inventory of DSR-7400 HD Series Transcoders. To guarantee sustained and uninterrupted delivery of services to your subscriber base, contact one of the following ARRIS-authorized distributors to purchase a shelf-spares backup unit:

Advanced Media Technologies

3150 SW 15th Street
 Deerfield Beach, FL 33442
 Phone 888.293.5856
 Fax 954.427.9688
 Contacts Ken Augustine and Neil Baruch

TVC Communications

10814 W. 78th Street
 Shawnee, KS 66214
 Phone 800.932.1555
 Fax 913-962-1806
 Contact Brent Scott

© 2020 CommScope, Inc. All rights reserved. No part of this content may be reproduced in any form or by any means or used to make any derivative work (such as translation, transformation, or adaptation) without written permission from CommScope, Inc. and/or its affiliates ("CommScope"). CommScope reserves the right to revise or change this content from time to time without obligation on the part of CommScope to provide notification of such revision or change. ARRIS and the ARRIS logo are trademarks of CommScope, Inc. and/or its affiliates. All other trademarks are the property of their respective owners.

CommScope provides this guide without warranty of any kind, implied or expressed, including, but not limited to, the implied warranties of merchantability and fitness for a particular purpose. CommScope may make improvements or changes in the product(s) described in this manual at any time.

The capabilities, system requirements and/or compatibility with third-party products described herein are subject to change without notice.

WARNING

The unauthorized modification of any unit and the sale and use of any such unit is prohibited by law. Any such modification or alteration of this product or any unauthorized reception of television programming could subject the user and seller and party modifying the unit to fines, imprisonment, and civil damages.

NOTE: This equipment has been tested and found to comply with the limits for a Class A digital device, pursuant to Part 15 of the FCC Rules. These limits are designed to provide reasonable protection against harmful interference when the equipment is operated in a commercial environment. This equipment generates, uses and can radiate radio frequency energy and, if not installed and used in accordance with the instruction manual, may cause harmful, interference to radio communications. Operation of this equipment in a residential area is likely to cause harmful interference in which case the user will be required to correct the interference at his own expense. This digital apparatus does not exceed the Class A limits of radio noise emissions from digital apparatus set out in the Radio Interference Regulations of the Canadian Department of Communications.

FCC Caution

Any changes or modifications not expressly approved by the party responsible for compliance could void the user's authority to operate this equipment.

Note to CATV System Installer

This reminder is provided to call the CATV system installer's attention to Article 820-40 of the National Electric Code (NEC) that provides guidelines for proper grounding and, in particular, specifies that the cable ground shall be connected to the grounding system of the building, as close to the point of cable entry as practical.

Warning

To prevent electrical shock, do not use the unit electrical power plug (polarized) with an extension cord, receptacle, or other outlet unless the blades can be fully inserted to prevent blade exposure. The mains disconnect device is the appliance plug and it shall remain readily accessible and operable.

Open Source Attributions: ARRIS DSR-7400 HD Series Commercial Integrated Transcoder / Receiver

Portions of the Software may contain or be derived from Open Source Software. The terms and conditions governing the use of such portions of the Software may be subject to the terms and conditions of the applicable Open Source Software License.

For instructions on how to obtain a copy of any source code being made publicly available by ARRIS related to software used in this ARRIS product, send a request in writing to the following address:

ARRIS Software Pedigree Operations
2450 Walsh Avenue
Santa Clara, CA, 95051, USA

OPERATION PRECAUTIONS

WARNING: TO PREVENT FIRE OR SHOCK HAZARD, DO NOT EXPOSE THIS EQUIPMENT TO RAIN OR MOISTURE.



The lightning flash with the arrowhead symbol, within an equilateral triangle, is intended to alert the user to the presence of un-insulated "dangerous voltage" within the product's enclosure that may be of sufficient magnitude to constitute a risk of electric shock to persons.



The exclamation point within an equilateral triangle is intended to alert the user to the presence of important operating and maintenance (servicing) instructions in the literature accompanying the product.

	CAUTION RISK OF ELECTRIC SHOCK DO NOT OPEN	
<p>CAUTION: TO REDUCE THE RISK OF ELECTRIC SHOCK, DO NOT REMOVE COVER (OR BACK). NO USER-SERVICEABLE PARTS INSIDE.</p> <p>REFER SERVICING TO QUALIFIED SERVICE PERSONNEL.</p>		

ATTENTION

This commercial unit is intended for the decoding of television signals for commercial use. Possession of this device does not enable or entitle the possessor to receive television signals. Contact Programmers to obtain appropriate authorizations.

Repairs and Assistance

For assistance with repair or return, see "Product Support" on page 18.

Important Safety Instructions

- Read these instructions.
 - Keep these instructions.
 - Heed all warnings.
 - Follow all instructions.
 - Do not use this apparatus near water.
 - Clean only with dry cloth.
 - Do not block any ventilation openings. Install in accordance with the manufacturer's instructions.
 - Do not install near any heat sources such as radiators, heat registers, stoves, or other apparatus (including amplifiers) that produce heat.
 - Do not defeat the safety purpose of the polarized or grounding-type plug. A polarized plug has two blades with one wider than the other. A grounding-type plug has two blades and a third grounding prong. The wide blade or the third prong is provided for your safety. If the provided plug does not fit into your outlet, consult an electrician for replacement of the obsolete outlet.
 - Protect the power cord from being walked on or pinched, particularly at plugs, convenience receptacles, and the point where they exit from the device.
 - Use only attachments and accessories specified by the manufacturer.
- Unplug this apparatus during lightning storms or when unused for long periods of time.
 - Refer all servicing to qualified service personnel. Servicing is required when the apparatus has been damaged in any way, such as when the power-supply cord or plug is damaged, liquid has been spilled, or objects have fallen into the apparatus, the apparatus has been exposed to rain or moisture, does not operate normally, or has been dropped.

Damage Requiring Service

If any of the following situations occur, unplug this equipment from the power source and contact a qualified repair service:

- If the power supply cord or plug is damaged.
- If liquid or objects have fallen into the unit.
- If the unit is wet from rain or water.
- If the unit was dropped or damaged.
- If the unit's performance changes.

Service

Do not try to service this product yourself. If you open or remove the cover, you may be exposed to dangerous voltage or other hazards and may void the unit's warranty. Contact a qualified service provider for all service.

Instrucciones importantes de seguridad

- Lea estas instrucciones.
- Conserve estas instrucciones.
- Preste atención a todas las advertencias.
- Siga todas las instrucciones.
- No utilice este aparato cerca del agua.
- Limpie únicamente con un trapo seco.
- No bloquee o tapas ninguna de las aberturas para ventilación. La instalación debe hacerse acorde con las instrucciones del fabricante.
- No se instale cerca de ninguna fuente de calor, tales como radiador, registros calientes, estufas, o cualquier otro aparato (incluyendo amplificadores) que produzcan calor.
- No anule el propósito de seguridad del enchufe polarizado o la conexión a tierra. El enchufe polarizado tiene dos terminales donde una es más ancha que la otra. El enchufe con conexión a tierra tiene las mismas dos terminales más una tercera en forma de punta que es la conexión a tierra. La terminal más ancha o la tercera punta en estos enchufes es para su seguridad. Si el enchufe suministrado no encaja en su toma, consulte a un electricista para que reemplace el tomacorriente obsoleto.
- Evite que el cable de alimentación de ser pisado o pellizcado en particular en los enchufes, tomacorrientes y en el punto por donde sale del aparato.
- Utilice únicamente los aditamentos y accesorios especificados por el fabricante.
- Desenchufe el aparato durante tormentas eléctricas o cuando no lo utilice durante largos períodos de tiempo.
- Remita todas las reparaciones a personal técnico calificado. Se requiere servicio cuando el aparato ha sido dañado de cualquier modo, como cuando el cable de alimentación o el enchufe está dañado, se ha derramado líquido o han caído objetos dentro del aparato, el aparato ha sido expuesto a la lluvia o la humedad, si no funciona normalmente, o se ha caído.

Daños que requieren servicio de mantenimiento

Desconecte el equipo de la fuente de alimentación y póngase en contacto con un proveedor de servicio en caso de alguna de las siguientes situaciones:

- Si el cable de corriente o el enchufe son dañados.
- Si líquidos u objetos caen dentro de la unidad.
- Si la unidad se moja por lluvia o derrame de agua.
- Si la unidad se ha caído o dañado.
- Si el rendimiento de la unidad cambia.

Servicio

No intente reparar este producto usted mismo. Si abre o retira la cubierta, podría exponerse a voltajes peligrosos u otros peligros, y puede anular la garantía de la unidad. Póngase en contacto con un proveedor de servicios autorizado de todos los servicios.

Contents

Chapter 1	Introducing the DSR-7400 HD Series	13
	Key Features.....	14
	New Features Supported in This Release	14
	DSR-7403 Signal Flow.....	15
	DSR-7406 Signal Flow.....	16
	DSR-7412 Signal Flow.....	17
	Product Support	18
	Calling for Repairs	18
Chapter 2	Installation	19
	Overview	19
	Rack Mounting Guidelines	19
	Mechanical Loading	19
	Ambient Temperature	19
	Circuit Overloading	20
	Earth Ground	20
	Special Instructions For Sweden and Finland.....	20
	Required Parts	20
	Physical Installation	21
	Quick Install	25
	LNB Power.....	27
	Network Setup	27
	Automatic RF Port Setup	31
	Configuring Keep Alive for DCII Subtitles	32
	Configuring SD Aspect Ratio	33
Chapter 3	Front Panel and Back Panel.....	35
	Front Panel	35
	Front-Panel Control Pushbuttons.....	36
	Back Panel.....	36
Chapter 4	Using the Menu System	37
	Overview	37
	Visual Indicators.....	37
	Navigating the Menu System	38
	Editing Fields Within the Menu System.....	39
	Using the Front-Panel LCD to Monitor Video.....	40

	Menu System Hierarchy.....	40
	Main Menu	41
	Quick Install Menu	41
	Satellite Video Distribution (RF Input).....	41
	CDN Video Delivery (HLS Input).....	42
	System Menu	43
	General Submenu.....	43
	Network Submenu	44
	Firmware Submenu.....	46
	Reset Submenu	47
	Input Menu	48
	Input Signal Submenu.....	48
	RF Input Submenu	48
	RF Tuner Submenu	49
	RF Port Setup Submenu.....	50
	ASI Input Submenu.....	51
	Channel Select Submenu	51
	Process Menu	52
	ASI Output Submenu	52
	IP Output Submenu	53
	Analog Output Submenu.....	53
	Status Submenu	55
	Control Status Submenu.....	55
	Input Status Submenu	56
	Process Status Submenu	58
	Diagnostics Menu	59
	Cue Tones Submenu	59
	Alarms Submenu	60
	Device Submenu.....	60
	Service Alarms Submenu.....	61
	Alarm Test Submenu	62
Chapter 5	Using the Web GUI to Configure IP Parameters.....	63
	Overview	63
	Reviewing/Changing IP Address Settings	64
	DHCP Supported Parameters and Auto-Fill Capabilities	65
	DHCP Implementation	66
Chapter 6	Viewing the Configuration Diagram.....	67
	Overview	67
	Basic Layout	69
	ToolTips	72
	Input Section - ASI Inputs, RF Inputs, and Tuners.....	72
	Processing Section - Channels and StatMuxes.....	74
	Output Section - Muxes, ASI Outputs, and IP Outputs.....	78
Chapter 7	Viewing NTP Servers	79
Chapter 8	Configuring UDP/IP Input and Output.....	81
	Overview	81
	Procedure	81

Chapter 9	Configuring CDN Streaming Services	87
	Overview	87
	Network Requirements	88
	Procedures	88
	Troubleshooting CDN Connectivity/Configuration Issues	90
	Viewing The Programmer's Service Information	91
Chapter 10	Downlink/L-Band Frequency Conversion Tables	95
Chapter 11	PID Mapping	97
Chapter 12	Upgrading Firmware Using the Web GUI	99
	Introduction	99
	Performing an Upgrade	100
Chapter 13	Managing SNMP Trap Receivers	103
Chapter 14	DSR-7400 HD Series Specifications	105

List of Figures

1	DSR-7403 Signal Flow	15
2	DSR-7406 Signal Flow	16
3	DSR-7412 Signal Flow	17
4	Connecting the 10-Pin Audio Terminal Block	21
5	Audio Pin Assignments	21
6	Connecting Cue Tone and Alarm Equipment to the Back Panel	22
7	Cue Tone and Alarm Pin Assignments	22
8	Connecting Cords and Cables to the Back Panel	24
9	Verifying the Front-Panel Signal LED and Authorized LED	26
10	Login Screen	30
11	Using the Help Screen to Download the Operator Guide	31
12	Keep Alive Dialog Box	32
13	Front-Panel LCD and LEDs	35
14	Front-Panel Control Buttons	36
15	Back Panel	36
16	Menu System - Visual Indicators (Example)	37
17	Status/Instruction Bar and Navigation Buttons (Example)	38
18	Editing Fields Within the Menu System (Example)	39
19	Viewing Video on the LCD	40
20	Menu System Hierarchy	40
21	Main Menu	41
22	Quick Install Menu - RF Input	41
23	Quick Install Menu - HLS Input	42
24	System Menu	43
25	General Submenu	43
26	Network Submenu	44
27	Firmware Submenu	46
28	Reset Submenu	47
29	Input Menu	48
30	Input Signal Submenu	48
31	RF Input Submenu	48
32	RF Tuner Submenu	49
33	RF Port Setup Submenu	50

34	ASI Input Submenu	51
35	Channel Select Menu	51
36	Process Menu	52
37	ASI Output Submenu	52
38	IP Output Submenu.....	53
39	Analog Output Submenu.....	53
40	Status Menu	55
41	Control Status Submenu	55
42	Input Status Submenu.....	56
43	Process Status Submenu.....	58
44	Diagnostics Menu.....	59
45	Cue Tones Submenus.....	59
46	Alarms Submenu.....	60
47	Device Alarms Submenu.....	60
48	Service Alarms Submenu.....	61
49	Alarm Test Submenu.....	62
50	Login Screen	63
51	System Network Screen.....	64
52	Network Submenu - Ethernet Port 1 Defaults That Assist With CDN Video Delivery	66
53	Transcoding Diagram - IO View (Example).....	67
54	Transcoding Diagram - Basic Layout (Example).....	68
55	Transcoding Diagram - Functionality (Example)	69
56	Transcoding Diagram - Color Designations (Example).....	70
57	Transcoding Diagram - Hidden StatMux Column (Example)	71
58	Transcoding Diagram ToolTips - Input Column (Input ASI, IP, and RF Ports).....	72
59	Transcoding Diagram ToolTips - Input Column (Tuners).....	73
60	Transcoding Diagram ToolTips - Processing Section - Channels Column	74
61	Transcoding Diagram ToolTips - Output Processor HD.....	75
62	Transcoding Diagram ToolTips - SD	77
63	Transcoding Diagram ToolTips - Output Section - Muxes Column	78
64	Editing Fields Within the IP Input Configuration Dialog Box (Example).....	81
65	Input Configuration Dialog Box - Channel Select and MPEG Select (Example).....	82
66	Connecting an IP Input Port to a Processor (Example).....	83
67	Viewing the Green Checkmark During Drag and Drop (Example).....	84
68	Configuring an IP Output Port's Destination Address Information (Example).....	84
69	Typical CDN Network Connectivity	87
70	Login Screen	91
71	Service Information Screen (Example).....	92
72	Viewing the Uplink's HLS Configuration Parameters (Example).....	93

List of Tables

1	Recommended Customer-Supplied Cables.....	20
2	10-Pin Terminal Block - Pin Assignments	21
3	Back-Panel 18-Pin Terminal Blocks - Pin Assignments	23
4	Decoder-Specific IP Address Information	28
5	Decoder Default IP Address Information.....	28
6	Keep Alive Parameters.....	32
7	DHCP Parameters Supported By The DSR-7400s.....	65

8	Transcoding Diagram ToolTips - Input Column (Input ASI, IP, and RF Ports).....	72
9	Transcoding Diagram ToolTips - Input Column (Tuners).....	74
10	Processing Section ToolTips - Channels Column and StatMuxes Column.....	75
11	Output Processor - Output Processor PT and HD	76
12	Output Processor SD	77
13	Transcoding Diagrams ToolTips - Muxes Section and Output Section.....	78
14	IP Input Configuration Parameters	82
15	IP Output Configuration Parameters	85
16	Quick Install Status Messages	90
17	Service Information Parameters.....	92
18	HLS Configuration Parameters	93
19	DSR-7400 HD Series - Default PID Assignments.....	97

List of Procedures (Alphabetical)

To access the unit's GUI	63
To authorize the transcoder / receiver.....	25
To configure a trap	104
To configure an IRD to receive DigiCipher Streaming services	88
To configure Keep Alive for DCII Subtitles	32
To configure RF IN Port 1 for LNB power	27
To configure the unit's Standard Definition aspect ratio.....	33
To configure UDP/IP Input	81
To configure UDP/IP output	84
To define the port setup	31
To determine if there is a need to configure the Ethernet ports	27
To download the operator guide to a personal computer.....	30
To edit a field.....	39
To manually change the unit's IP address settings.....	65
To navigate the menu system	38
To perform the physical install.....	21
To set new IP address information.....	29
To ship equipment for repair	18
To upgrade the decoder's firmware version	100
To view Service Information	91
To view the Transcoding Diagram.....	68

Introducing the DSR-7400 HD Series



The unit's model number (DSR-7403, DSR-7406, or DSR-7412) is engraved here on the front panel.

IMPORTANT: This Operator Guide only applies to the DSR-7403, DSR-7406, and DSR-7412. This Operator Guide does not apply to the DSR-7401.

The ARRIS DSR-7400 HD Series commercial satellite Transcoder / Receiver provides connectivity to existing headend equipment for easy installation and deployment. The unit is designed for broadcasters and headend operators for receiving digital satellite services and also supports DigiCipher® Streaming Service for program delivery through Internet Content Distribution Networks. This multi-channel unit has an integrated design, combining traditional IRD functions and transcoding functions into a single 1RU unit. The DSR-7403 can transcode up to three input channels/services. The DSR-7406 can transcode up to six input channels/services. The DSR-7412 can transcode up to 12 input channels/services. All three units output MPEG-4/MPEG-2 HD and SD video.

The unit can process transport streams from the Asynchronous Serial Interface (ASI) input port and from the four RF input ports. The unit can also process transport streams from Gigabit Ethernet (either Gigabit Ethernet 1 or Gigabit Ethernet 2). The unit generates transcoded output services on the two ASI output ports and on the two Gigabit Ethernet output ports (Gigabit Ethernet 3 and Gigabit Ethernet 4).

This document describes the unit at firmware version **0x340eXX**. To verify the firmware version, press **Menu** several times until the **Main Menu** appears, press **▼** to highlight **System**, press **OK**, press **▼** to highlight **Firmware**, press **OK**, and verify that the **Version** field displays **0x340eXX**. To view the firmware version remotely, see Figure 51 on page 64.

Key Features

- DSR-7412 only
 - Transcodes and down converts up to 12 input services to MPEG-2/MPEG-4 HD and SD for Cable/Telco/Satellite distribution when fully licensed.
- DSR-7406 only
 - Transcodes and down converts up to six input services to MPEG-2/MPEG-4 HD and SD for Cable/Telco/Satellite distribution when fully licensed.
- DSR-7403 only
 - Transcodes and down converts up to three input services to MPEG-2/MPEG-4 HD and SD for Cable/Telco/Satellite distribution when fully licensed.
- DSR-7403 only
 - Broadcast quality analog output for cable distribution.
 - DTMF tone output triggered by DTMF Descriptors included in SCTE-35 messages received from the Programmer.
 - Unit simultaneously receives transport streams from up to four satellite transponders.
 - UDP/IP and ASI input support.
 - Dedicated cue tone port for each input service.
 - Pass thru option for all input services.
 - HEVC and MPEG-4 inputs supported.
 - AFD processing support for video down conversion (center cut, letterbox, 14:9 and 16:9).
 - Web browser access for configuration information and user documentation.
 - One RU chassis design.
 - One Form-C relay for fault alarm indication.
 - Four RF input ports (L-Band).
 - Advanced Modulation support with DCII QPSK, DVB-S2 8PSK/16APSK, DVB-S2x 8PSK/16APSK, and 8PSK Turbocodes.
 - Two ASI output ports.
 - Five Gig-E interfaces for media and control.
 - One analog composite video output port. One composite video monitoring output port.
 - DigiCipher II conditional access system support.
 - Front-panel confidence monitor for viewing video on LCD screen.
 - DPI (Ad Insertion) forward / passthrough.
 - Tier-based DPI message filtering.
 - Configurable closed loop statmux output groups.
 - SNMP monitoring support. For details, contact ARRIS Product Support (described on page 18).
 - DCII and DVB subtitle overlay on transcoded video.

New Features Supported in This Release

- License Required
 - DigiCipher Streaming Service for program delivery through Internet Content Distribution Networks.
 - Ethernet Interface Setup Modes: DHCP or Manual.
 - DNS Support for FQDN resolution.
 - Synchronize System Time via NTP.
 - ASI/IP firmware upgrade.
 - DTMF descriptor filtering on SCTE-35 passthrough.

DSR-7403 Signal Flow

Figure 1 shows an overview of the DSR-7403’s signal flow. This unit has seven input ports, four tuners, and three processors. Each processor can output three services (transcoded HD, transcoded SD, and Pass Thru). These three output services can be routed to any combination of the four output ports (ASI 1, ASI 2, ETH3, and/or ETH4).

Seven Ports For Input

Connect one or more of the input ports (RF 1, RF 2, RF 3, RF 4, ASI IN, ETH1, and ETH2).

Four Tuners For Receiving Signals

Each tuner receives a single RF input from any RF port. For IP Input, use the web GUI to specify either ETH1 or ETH2.

Three Processors For Transcoding

Each licensed processor transcodes an input service and routes it to one, two, or three output services (High Definition, Standard Definition, and Pass Thru).

Five Muxes For Multiplexing

One or more transcoded or pass thru output services are combined into transport stream output multiplexes.

Four Ports For Output

Output services are routed to one or more output ports. ASI 1 and ASI 2 can receive only one multiplex at a time. ETH3 and ETH4 can output multiple multiplexes.

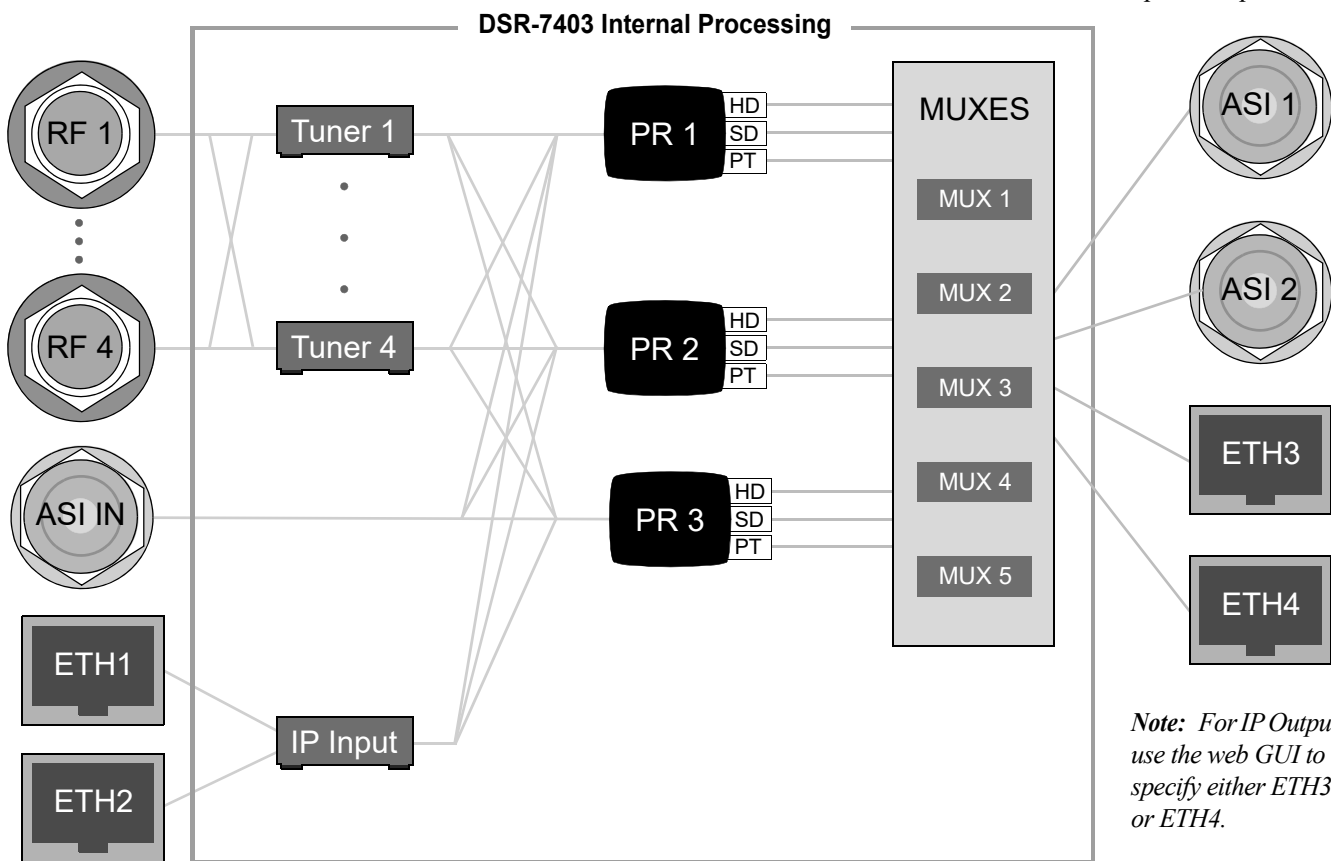

Note: The DSR-7403 includes one standard transcoding license. A fully-licensed DSR-7403 can transcode up to three MPEG-4 or HEVC input video services to MPEG-2 or MPEG-4 format for output. If it is necessary to purchase transcoding licenses, contact your ARRIS account representative or the authorized distributor.

Note: The DSR-7403 supports IP input from one Ethernet port at a time. The Ethernet port labeled CONTROL is used to access the unit’s web GUI and to download the Operator Guide (this document).

Figure 1: DSR-7403 Signal Flow

DSR-7406 Signal Flow

Figure 2 shows an overview of the DSR-7406’s signal flow. This unit has seven input ports, four tuners, and six processors. Each processor can output three services (transcoded HD, transcoded SD, and Pass Thru). These three output services can be routed to any combination of the four output ports (ASI 1, ASI 2, ETH3, and/or ETH4).

Seven Ports For Input

Connect one or more of the input ports (RF 1, RF 2, RF 3, RF 4, ASI IN, ETH1, and ETH2).

Four Tuners For Receiving Signals

Each tuner receives a single RF input from any RF port.
For IP Input, use the web GUI to specify either ETH1 or ETH2.

Six Processors For Transcoding

Each licensed processor transcodes an input service and routes it to one, two, or three output services (High Definition, Standard Definition, and Pass Thru).

Eight Muxes For Multiplexing

One or more transcoded or pass thru output services are combined into transport stream output multiplexes.

Four Ports For Output

Output services are routed to one or more output ports. ASI 1 and ASI 2 can receive only one multiplex at a time. ETH3 and ETH4 can output multiple multiplexes.

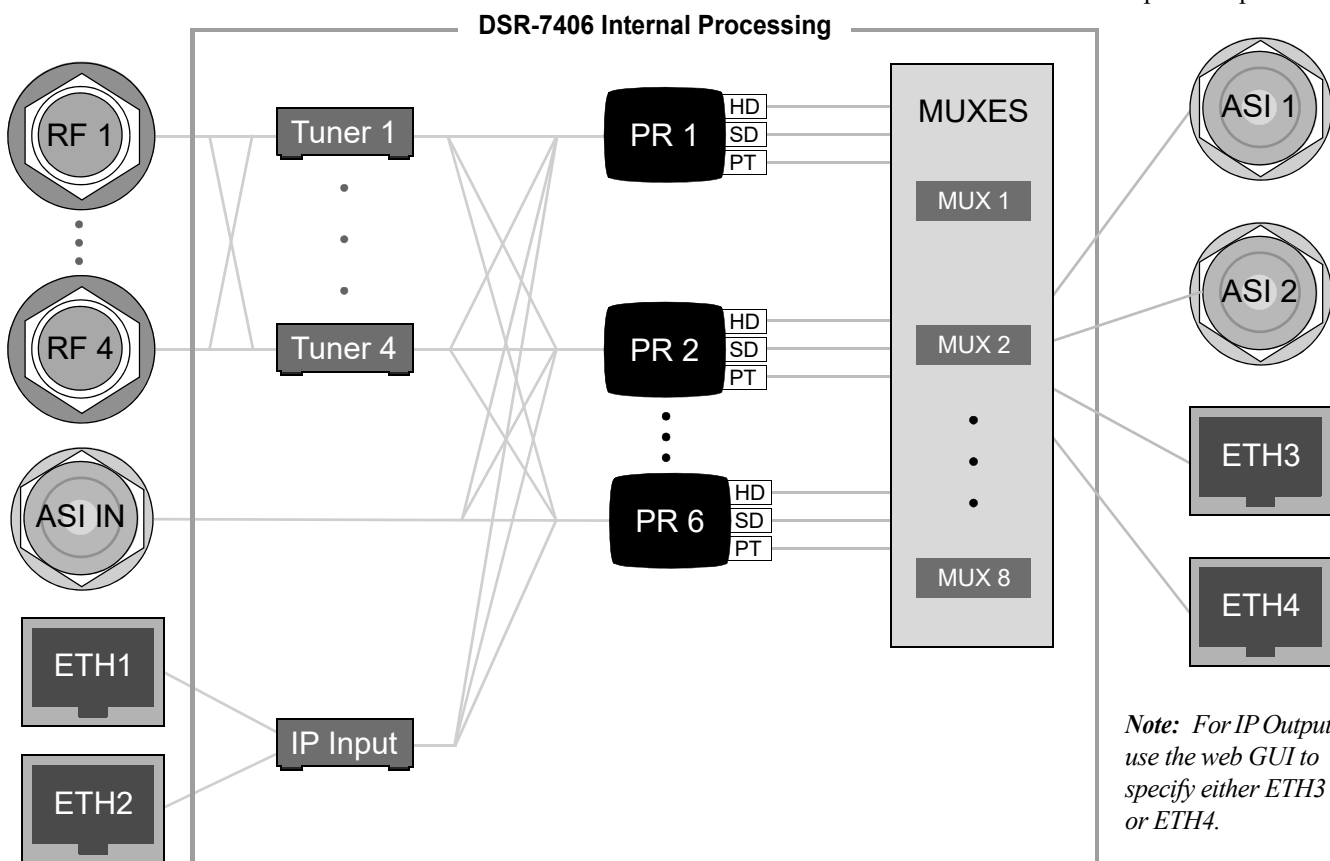

Note: For IP Output, use the web GUI to specify either ETH3 or ETH4.

Note: The DSR-7406 includes four standard transcoding licenses. A fully-licensed DSR-7406 can transcode up to six MPEG-4 or HEVC input video services to MPEG-2 or MPEG-4 format for output. If it is necessary to purchase transcoding licenses, contact your ARRIS account representative or the authorized distributor.

Note: The DSR-7406 supports IP input from one Ethernet port at a time. The Ethernet port labeled CONTROL is used to access the unit’s web GUI and to download the Operator Guide (this document).

Figure 2: DSR-7406 Signal Flow

DSR-7412 Signal Flow

Figure 3 shows an overview of the DSR-7412’s signal flow. This unit has seven input ports, four tuners, and twelve processors. Each processor can output three services (transcoded HD, transcoded SD, and Pass Thru). These three output services can be routed to any combination of the four output ports (ASI 1, ASI 2, ETH3, and/or ETH4).

Seven Ports For Input

Connect one or more of the input ports (RF 1, RF 2, RF 3, RF 4, ASI IN, ETH1, and ETH2).

Four Tuners For Receiving Signals

Each tuner receives a single RF input from any RF port.
For IP Input, use the web GUI to specify either ETH1 or ETH2.

Twelve Processors For Transcoding

Each licensed processor transcodes an input service and routes it to one, two, or three output services (High Definition, Standard Definition, and Pass Thru).

Fourteen Muxes For Multiplexing

One or more transcoded or pass thru output services are combined into transport stream output multiplexes.

Four Ports For Output

Output services are routed to one or more output ports. ASI 1 and ASI 2 can receive only one multiplex at a time. ETH3 and ETH4 can output multiple multiplexes.

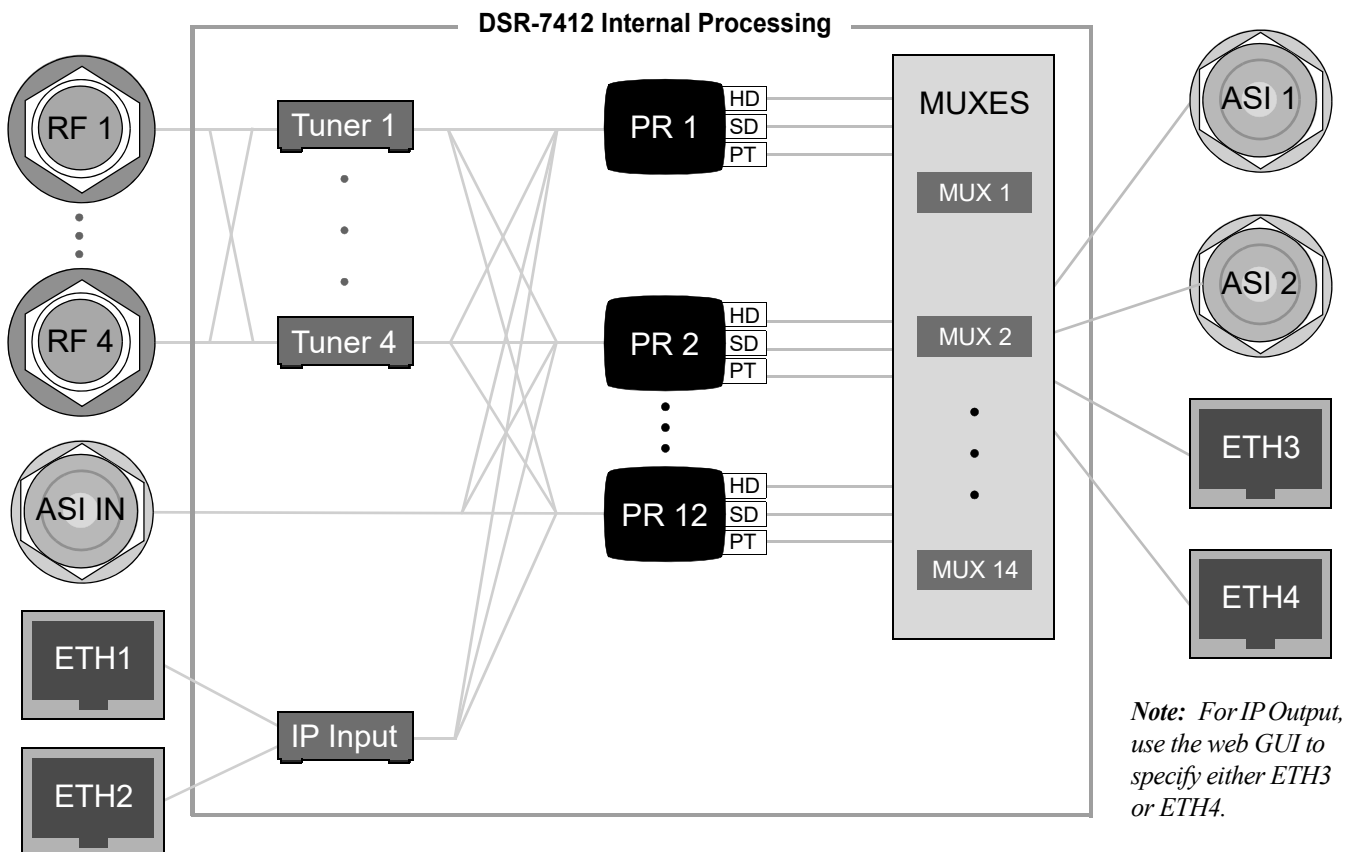

Note: The DSR-7412 includes ten standard transcoding licenses. A fully-licensed DSR-7412 can transcode up to twelve MPEG-4 or HEVC input video services to MPEG-2 or MPEG-4 format for output. If it is necessary to purchase transcoding licenses, contact your ARRIS account representative or the authorized distributor.

Note: The DSR-7412 supports IP input from one Ethernet port at a time. The Ethernet port labeled **CONTROL** is used to access the unit’s web GUI and to download the Operator Guide (this document).

Figure 3: DSR-7412 Signal Flow

Product Support

Help with the unit is available by phone and online. For assistance, use one of the following:

- Technical Assistance Center (TAC) provides access to technicians 24 hours a day, 7 days a week for all products. To open a case, use one of the following telephone numbers:
 - Customers in North America should call the TAC at 888-944-HELP (888-944-4357).
 - Customers outside North America should call the TAC at IDD (International Direct Dialing Number) + 1 + 215-323-2345.
 - For Spanish language support, call 215-323-2346.
- Contact the TAC by email at tac.helpdesk@arris.com.
- The ARRIS Training Learning Portal (<http://www.arris.com/support/training>) provides self-paced product training and course descriptions of instructor-led training classes. In many cases, training can be given at your location.

Calling for Repairs

If repair is necessary, call 1-888-944-4357 for the shipping address and a Return for Service Authorization (RSA) number before sending the unit for repair. The RSA number must be prominently displayed on all equipment cartons and shipping labels.

To ship equipment for repair

1. Pack the unit securely.
2. Enclose a note describing the exact problem.
3. Enclose a copy of the invoice to verify the warranty status.
4. Label all cartons and shipping labels with the RSA number.

Installation

Overview

Use this chapter with the ARRIS DSR-7400 HD Series Transcoder / Receiver at firmware version **0x340eXX**. The instructions in this section describe how to install the unit and access the Operator Guide. The information in this chapter is the same content as the *ARRIS DSR-7400 HD Series Installation Guide*.

Rack Mounting Guidelines

The DSR-7400 HD Series, with the supplied mounting brackets, is designed for installation in an EIA standard 19-inch (480 mm) equipment rack. If multiple units are installed in a rack assembly, the operator may choose to have a certification agency to evaluate the condition of the rack. Place each unit in a stable and level position within the rack and ensure that all front-enclosure screws are tightened to 14 in-lbs.

Mechanical Loading

The mounting rack location should be secure and level to avoid hazardous instability to the equipment due to uneven loading or weight distribution within the rack.

Ambient Temperature

When installing a unit within a closed or multi-unit rack, the ambient temperature may be greater than the ambient temperature within the room. Therefore, verify that the amount of air flow required for safe operation is not compromised (maximum temperature for the equipment is 40° C [104° F]). Consideration should be given to the maximum rated ambient temperature for the unit's location when planning for cooling and air circulation. To evacuate the unit's warm air output from within the mounting rack, ARRIS recommends the use of a fan on top of the rack.

Circuit Overloading

If the unit is connected to a power strip, rather than a branch circuit's direct connection, use special care to ensure that the unit is properly connected. Always consider the affect that overloading circuits might have on over-current protection and supply wiring. To ensure that circuits are not overloaded, read the unit's UL regulatory power label on top of the unit. Check all equipment power/amperage ratings to ensure the mounting rack power rating is not exceeded.

Earth Ground

Reliable earthing of rack-mounted equipment should be maintained. Particular attention should be given to supply connections other than direct connections to the branch circuit (e.g., use of power strips). The RF-IN antenna cable should only be connected while the unit is properly grounded. The shield of the coaxial cable should be earthed in YP accordance with Article 820.93 of the NEC (National Electrical Code), ANSI/NFPA 70:2005, or equivalent.

Special Instructions For Sweden and Finland

For restricted access locations, install the DSR-7400 HD Series Transcoder/Receiver only in restricted-access areas (dedicated equipment rooms, equipment closets, or the like) in accordance with Articles 110-26, 110-27, or the NEC ANSI/NFPA70, or per the applicable code in the country of installation.

Required Parts

The procedures in this section require the following items:

- DSR-7400 HD Series Transcoder / Receiver
- Power cord [included with unit]
- Two 18-pin terminal block plugs (for cue tones and alarm relays) [included with unit]
- One 10-pin terminal block plug (for audio monitoring) [included with unit]

Table 1 lists recommended cables to be supplied by the customer.

Table 1: Recommended Customer-Supplied Cables

Interface	Connector	Type	Cable
RF	75 Ω F-Connector	Coax	Belden 1694A (or equivalent)
ASI	75 Ω BNC	Coax	Belden 1694A (or equivalent)
Analog Video			
DTMF/Cue Tone	Phoenix Terminal Block	STP	Belden 8451 (or equivalent)
Audio			
Alarm			
Ethernet	RJ-45	4x2 U/UTP	CAT5e

Physical Installation

To perform the physical install

1. Remove the unit from the packing box and install it in the rack, as described on pages 19 and 20.

Optional

2. If it is necessary to monitor audio, use Figure 4 to connect the 10-pin terminal block.

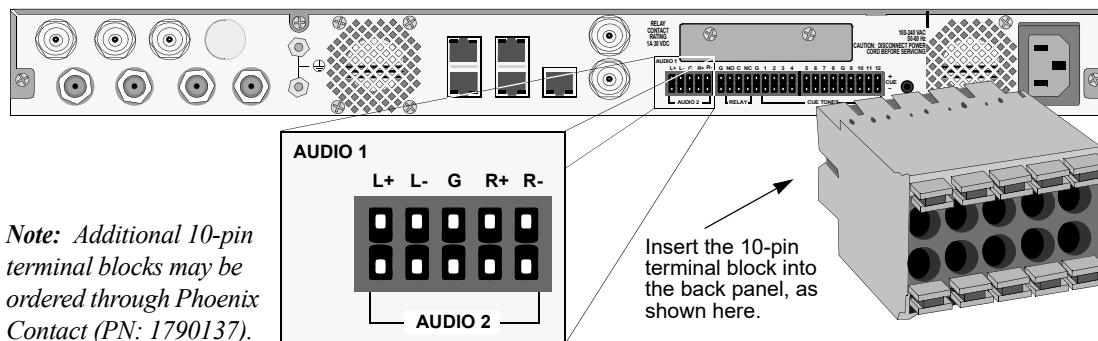

Figure 4: Connecting the 10-Pin Audio Terminal Block

Optional

3. Use Figure 5 and Table 2 to make the necessary connections to the site's audio monitoring equipment.

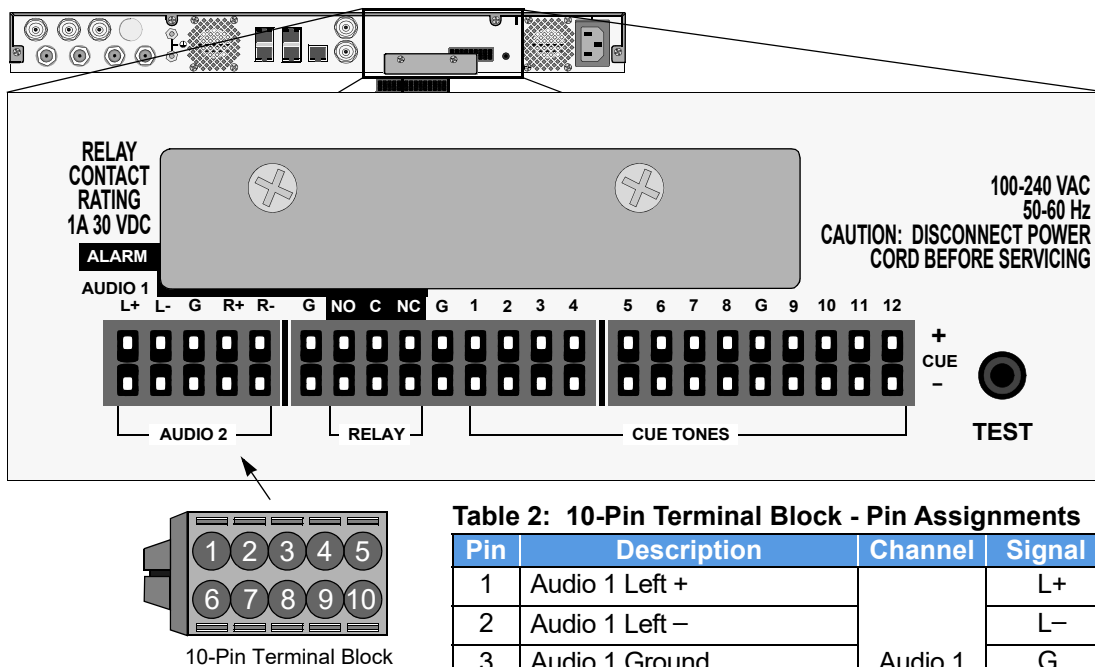

Table 2: 10-Pin Terminal Block - Pin Assignments

Pin	Description	Channel	Signal
1	Audio 1 Left +	Audio 1	L+
2	Audio 1 Left -		L-
3	Audio 1 Ground		G
4	Audio 1 Right +		R+
5	Audio 1 Right -		R-
6	Audio 2 Left +	Audio 2	L+
7	Audio 2 Left -		L-
8	Audio 2 Ground		G
9	Audio 2 Right +		R+
10	Audio 2 Right -		R-

Figure 5: Audio Pin Assignments

- Optional** 4. If it is necessary to provide cue tones or install an alarm, connect one or both 18-pin terminal blocks, as shown in Figure 6.

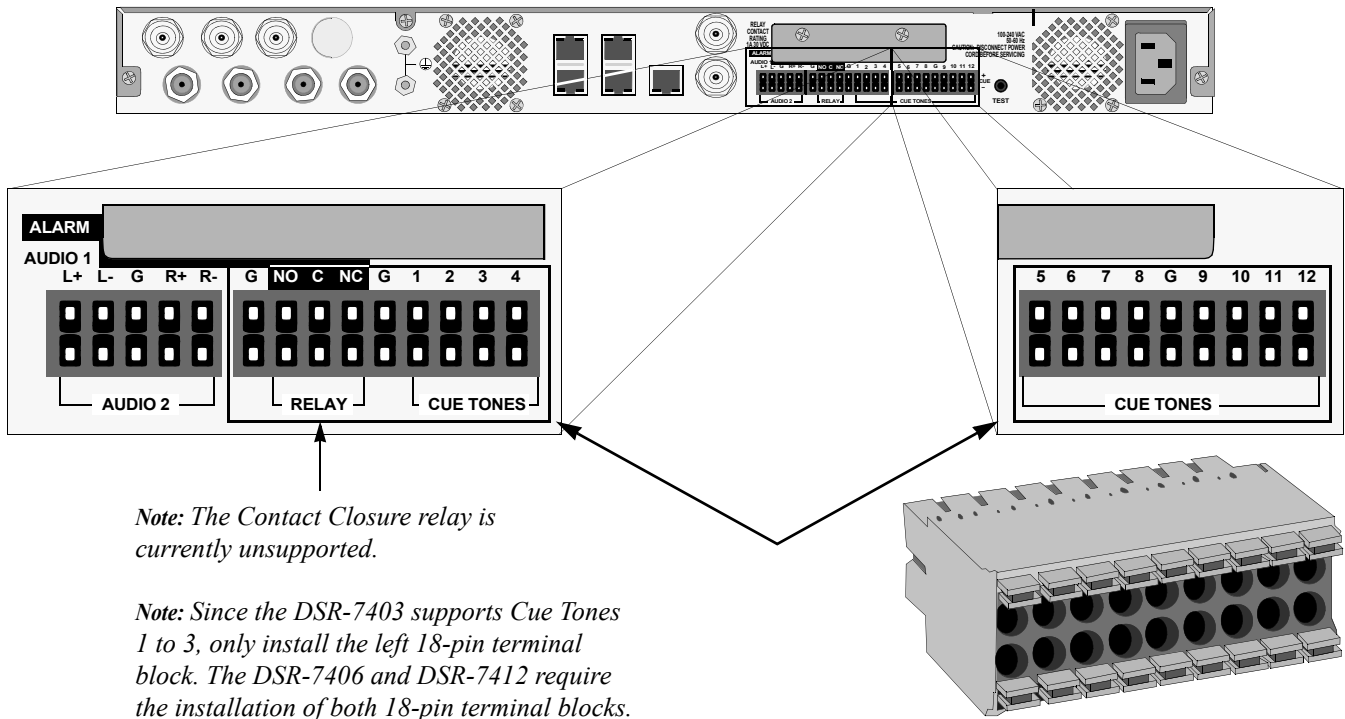

Figure 6: Connecting Cue Tone and Alarm Equipment to the Back Panel

- Optional** 5. Use Figure 7 to make the necessary connections to the site’s cue tone and alarm equipment. Pin assignments are described in Table 3 on page 23.

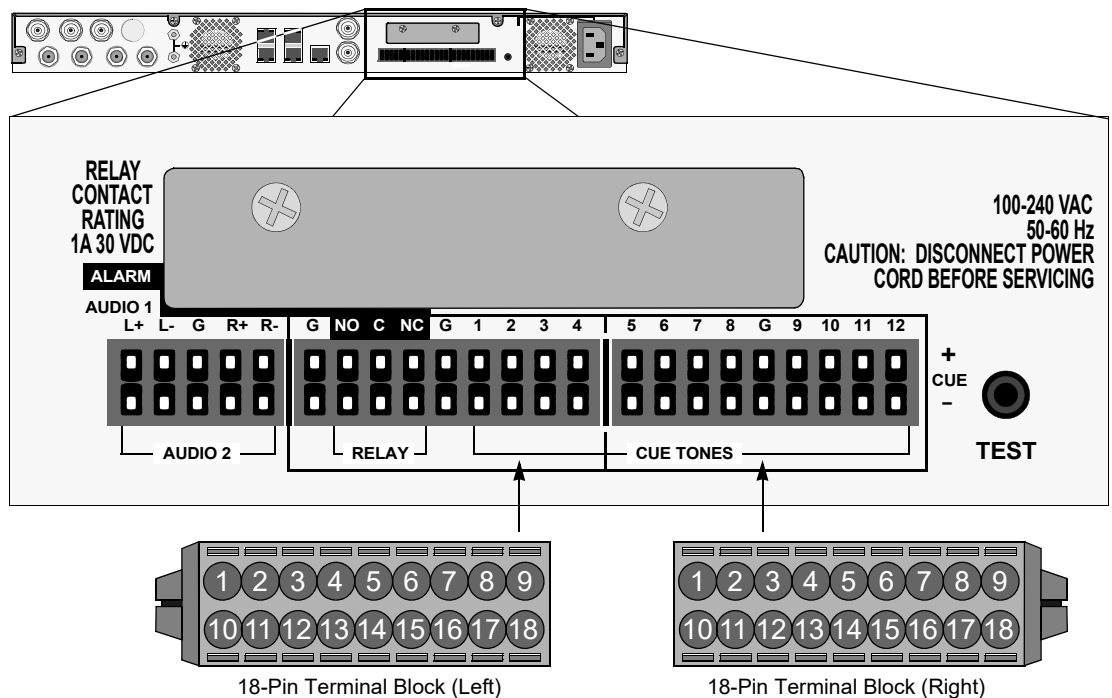

Figure 7: Cue Tone and Alarm Pin Assignments

Table 3: Back-Panel 18-Pin Terminal Blocks - Pin Assignments

Location	Pin	Description	Signal	Device
18-pin Terminal (Left)	1	Alarm Relay Ground	G	Alarm Relay
	2	Alarm Relay Normally Open Circuit	NO	
	3	Alarm Relay Common	C	
	4	Alarm Relay Normally Closed Circuit	NC	
	5	Cue Tones Ground	G	Cue Tones
	6	Cue Tone 1 +	+	
	7	Cue Tone 2 +	+	
	8	Cue Tone 3 +	+	
	9	Cue Tone 4 +	+	
	10	Relay Ground	G	(These Relay Pins are reserved for future use.)
	11	Relay Normally Open Circuit	NO	
	12	Relay Common	C	
	13	Relay Normally Closed Circuit	NC	
	14	Cue Tones Ground	G	Cue Tones
	15	Cue Tone 1 –	–	
	16	Cue Tone 2 –	–	
	17	Cue Tone 3 –	–	
	18	Cue Tone 4 –	–	

18-pin Terminal (Right)	1	Cue Tone 5 +	+	Cue Tones
	2	Cue Tone 6 +	+	
	3	Cue Tone 7 +	+	
	4	Cue Tone 8 +	+	
	5	Cue Tones Ground	G	
	6	Cue Tone 9 +	+	
	7	Cue Tone 10 +	+	
	8	Cue Tone 11 +	+	
	9	Cue Tone 12 +	+	
	10	Cue Tone 5 –	–	
	11	Cue Tone 6 –	–	
	12	Cue Tone 7 –	–	
	13	Cue Tone 8 –	–	
	14	Cue Tones Ground	G	
	15	Cue Tone 9 –	–	
	16	Cue Tone 10 –	–	
	17	Cue Tone 11 –	–	
	18	Cue Tone 12 –	–	

Note: DSR-7403 supports Cue Tones 1 to 3.
 DSR-7406 supports Cue Tones 1 to 6.
 DSR-7412 supports Cue Tones 1 to 12.

Note: Additional 18-pin terminal blocks may be ordered through Phoenix Contact (PN: 1790179).

Note: If it is necessary to test cue tones, see "Cue Tones Submenu" on page 59.

IMPORTANT: The following steps pertain specifically to Satellite Video Distribution. If it is necessary to authorize the receiver for CDN Video Delivery (HLS), do not perform the following steps in this chapter. Instead, see Chapter 9, "Configuring CDN Streaming Services" on page 87.

6. Connect the RF ports and output ports as directed by the Programmer and attach the power cord to the unit's power connector. Connect cords and cables, as shown in Figure 8.

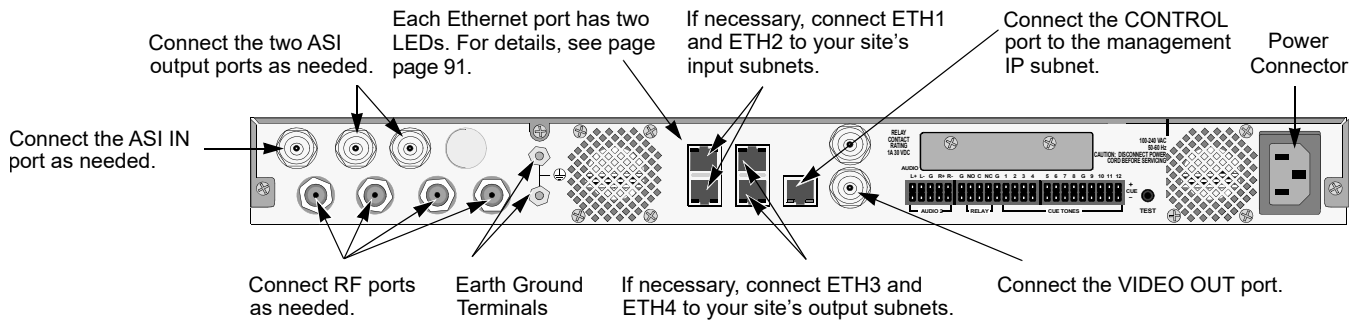

Figure 8: Connecting Cords and Cables to the Back Panel

Note: The Programmer may give specific instructions about how to connect the RF inputs. These instructions must be followed to ensure proper operation. Please consult directions provided by the Programmer.

CAUTION: When connecting any of the RF IN ports, the RF-IN Antenna cable should only be connected while the unit is properly grounded and the shield of the coaxial cable should be earthed in accordance with Article 820.93 of the NEC, ANSI/NFPA 70:2005 or equivalent.

7. Connect the earth ground to the two grounding terminals (shown in Figure 8) and torque both nuts to 12 in-lbs. ARRIS recommends the use of the following grounding lug connector:

Panduit (pn: LCD6-10AF-L) or similar

8. If the Operator Guide PDF is not yet downloaded to a personal computer (PC), connect the CONTROL port and a personal computer to the same subnet. The PDF will be downloaded later on page 30.

Quick Install

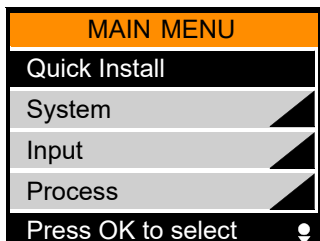

To authorize the transcoder / receiver

IMPORTANT: This procedure pertains specifically to Satellite Video Distribution. If it is necessary to authorize the receiver for CDN Video Delivery (HLS), do not perform the following procedure. Instead, see Chapter 9, "Configuring CDN Streaming Services" on page 87.

This procedure describes how to set up the initial input port, verify that the signal is present, and have the Programmer authorize the unit. Once the initial signal is established, the Programmer will supply the unit with the rest of the configuration. Therefore, there is no need to use the front panel to configure the other input ports.

IMPORTANT: The Quick Install menu is designed to configure only one RF port as an input port. Do not attempt to configure more than one RF input port using the Quick Install menu. If you wish to configure more than one RF port, do not perform this procedure. Instead, see "Channel Select Submenu" on page 51.

1. Obtain the following information from the Programmer to configure the initial input port. Write the information in the table below.

Input Port	Write the information here ↓			
	Frequency	Transponder	Modulation Mode	Symbol Rate (MSPS)

2. Power up the unit and press **Menu** button until the Main Menu appears.
3. Use the **▲ ▼** buttons to move to the **Quick Install** menu (shown below) and press **OK**.

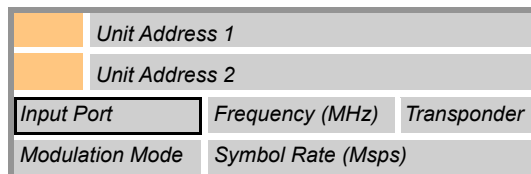
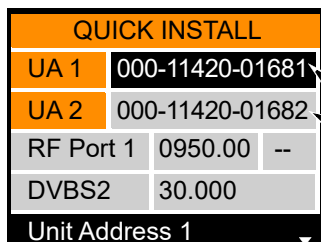

Note: The Programmer will need to know both unit addresses.

4. Write the Unit Addresses in the following table and give the Programmer this information.

Unit Address Information	Write the information here ↓
Unit Address 1	
Unit Address 2	

5. Use the ▲ ▼ buttons to move to the **Input Port** field, press **OK** to enter the field, use the ▲ ▼ buttons to choose the input port from step 1 and press **OK** to exit the field.
6. Configure either the **Frequency** field or the **Transponder** field. To do this, use the arrow buttons (▲ ▼ ◀ ▶) to move to the field, press **OK** to enter the field, use the arrow buttons (▲ ▼ ◀ ▶) to specify the Frequency or Transponder from step 1, and press **OK** to exit the field.
7. Use the arrow buttons (▲ ▼ ◀ ▶) to move the cursor to the **Modulation Mode** field, press **OK** to enter the field, use the ▲ ▼ buttons to specify the Modulation Mode from step 1, and press **OK** to exit the field.
8. Use the arrow buttons (▲ ▼ ◀ ▶) to move the cursor to the **Symbol Rate** field, press **OK** to enter the field, use the arrow buttons (▲ ▼ ◀ ▶) to specify the Symbol Rate from step 1, and press **OK** to exit the field.
9. Verify that the **Signal** LED illuminates green, as shown in Figure 9.
10. Contact the Programmer to authorize the unit. Tell the Programmer the unit's model number (either DSR-7403, DSR-7406, or DSR-7412).

Note: The Programmer may ask you to verify several port connections, including what network feeds are attached to the RF port(s). Make any changes as directed by the Programmer. If the Programmer asks you to perform an automatic port setup, see "Automatic RF Port Setup" on page 31.

11. Verify that both LEDs are illuminated green (**Signal** and **Authorized**), as shown in Figure 9.

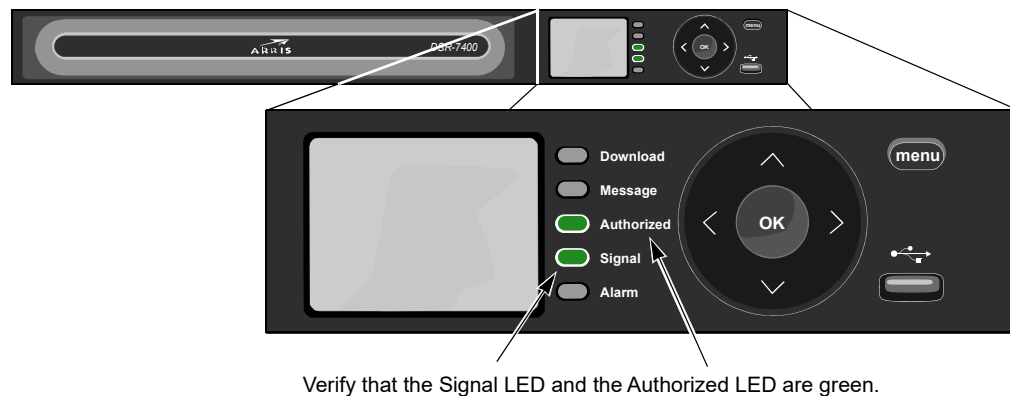

Figure 9: Verifying the Front-Panel Signal LED and Authorized LED

Note: Once the unit is authorized, the Programmer will automatically supply the unit with the rest of the configuration.

12. To verify the current program(s), press **Menu** until the program video appears on the LCD screen.
13. To manipulate the video LCD screen:
 - To choose the desired video source to monitor, use the ▲ ▼ buttons.
 - To scroll the on-screen video description, use the ◀ ▶ buttons.
 - To toggle (show and hide) the video description, press the **OK** button.
 - To return to the menu system while a video is being displayed on the LCD screen, press **Menu**.

LNB Power

Optional

If it is necessary to provide 18 VDC LNB power to the RF IN Port 1 on the back panel, perform the following procedure.

To configure RF IN Port 1 for LNB power

1. Navigate to the **RF Port Setup Submenu** and set the **LNB** parameter to **On**. To do this, perform the following bullets:
 - To navigate to the RF Port Setup Submenu:
Press the **menu** button until the **Main Menu** appears, use the **▲ ▼** buttons to highlight **Input**, press **OK**, highlight **Input Signal**, press **OK**, highlight **RF Input**, press **OK**, highlight **RF Port Setup**, and press **OK**.
 - To set the LNB parameter to On:
Use the **▲ ▼** buttons to highlight the **RF Port Number** parameter, press **OK**, choose **RF Port 1**, press **OK**, highlight the **LNB Power** parameter, press **OK**, choose **ON**, and press **OK**.
2. Verify that the RF Port Setup menu matches the following illustration.

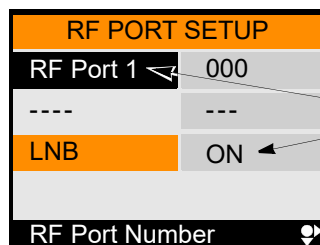

Choose RF Port 1
Choose ON

Note: This parameter is not set by the Programmer. This parameter can only be set from the front panel.

Optional

3. To return to the menu system while a video is being displayed on the LCD screen, press **menu**.

Network Setup

Optional

To determine if there is a need to configure the Ethernet ports

1. Consider the following bullets:
 - If you plan to distribute video services via the unit's GigE ports, you will need to configure ports ETH3 and ETH4 for the subnets at your site.
 - If you have not downloaded the Operator Guide PDF file from the unit to a PC, you will need to configure the Control port for your site.
 - If you plan to use a Web GUI to review the unit's Configuration Diagram, you will need to configure the Control port for your site.

IMPORTANT: When planning the configuration of the Ethernet ports on the back panel, always make sure that each Ethernet port has a unique subnet address.

2. If it is necessary to configure one or more Ethernet ports, contact your site's system administrator for the following information. For non-DHCP configurations, write the information in Table 4 on page 28. This information will be used when you configure the Ethernet ports.

Table 4: Decoder-Specific IP Address Information

	Ethernet Port Information	Write the address here ↓	Purpose
Must be configured in order to receive video services via GigE input ports.	Ethernet Port 1 IP Address		Input Only
	Ethernet Port 1 Subnet Mask		
	Ethernet Port 1 Gateway Address		
	Ethernet Port 2 IP Address		Input Only
	Ethernet Port 2 Subnet Mask		
	Ethernet Port 2 Gateway Address		
Must be configured in order to distribute video services via GigE output ports.	Ethernet Port 3 IP Address		For Satellite Video Distribution and CDN Video Delivery; Output only.
	Ethernet Port 3 Subnet Mask		
	Ethernet Port 3 Gateway Address		
	Ethernet Port 4 IP Address		For Satellite Video Distribution and CDN Video Delivery; Output only.
	Ethernet Port 4 Subnet Mask		
	Ethernet Port 4 Gateway Address		
	Control Port IP Address		Obtain Operator Guide and Remote Monitoring.
	Control Port Subnet Mask		
	Control Port Gateway Address		

IMPORTANT: By default, the Ethernet 1 port is configured to use a DHCP server for all IP address information. If the IP address information is not resolved by the DHCP server, the IP Address is set to 0.0.0.0.

However, when Ethernet 1 port uses the Static option, the operator will manually-define all IP address information for the Ethernet 1 port. (See Table 4, above). If the Static option is specified and the IP Address information is not entered, the factory-defined IP address information (shown in Table 5) will remain active.

For details about the DHCP option and the Static option, see Host Config on page page 44.

Table 5: Decoder Default IP Address Information

Ethernet Port Information	Factory Defaults
Ethernet Port 1 IP Address	192 . 168 . 1 . 100
Ethernet Port 1 Subnet Mask	255 . 255 . 255 . 0
Ethernet Port 1 Gateway Address	192 . 168 . 1 . 1
Ethernet Port 2 IP Address	192 . 168 . 2 . 100
Ethernet Port 2 Subnet Mask	255 . 255 . 255 . 0
Ethernet Port 2 Gateway Address	192 . 168 . 2 . 1
Ethernet Port 3 IP Address	192 . 168 . 3 . 100
Ethernet Port 3 Subnet Mask	255 . 255 . 255 . 0
Ethernet Port 3 Gateway Address	192 . 168 . 3 . 1
Ethernet Port 4 IP Address	192 . 168 . 4 . 100
Ethernet Port 4 Subnet Mask	255 . 255 . 255 . 0
Ethernet Port 4 Gateway Address	192 . 168 . 4 . 1
Control Port IP Address	192 . 168 . 0 . 100
Control Port Subnet Mask	255 . 255 . 255 . 0
Control Port Gateway Address	192 . 168 . 0 . 1

To set new IP address information

IMPORTANT: For information about Content Delivery Network (CDN) configurations, see Chapter 9, "Configuring CDN Streaming Services" on page 87.

IMPORTANT: If you have not yet downloaded the Operator Guide PDF from the unit to a PC, perform this procedure so you can configure the **Control** port. If you plan to use Ethernet input or output, perform this procedure.

Use the front panel to change the IP address information that you wrote down on page 28. This procedure will describe how to enter the IP address information for one or more Ethernet ports. If you already know how to do this, do it now, and then skip to the next procedure. For specific instructions on how to change these three addresses, perform the following steps:

1. Go to the front panel and press the **Menu** button until the Main Menu appears.
2. Use the **▲ ▼** buttons to move to the **System** menu and press the **OK** button.
3. Use the **▲ ▼** buttons to move to the **Network** menu and press the **OK** button.
4. Within the Network menu, use the **▲ ▼** buttons to move to the **Ethernet Port** field (top left field), press **OK** to enter the field and use the **▲ ▼** buttons to choose the Ethernet port to configure (either ETH3, ETH4, or Control). Then, press **OK** to exit the field.
5. Use the arrow buttons (**▲ ▼ ◀ ▶**) to move the cursor to the **IP Address** field and press **OK** to enter the field.
6. Use the arrow buttons (**▲ ▼ ◀ ▶**) to enter the port's IP Address. The unit's IP address information is in the table on page 28.

Note: To enter the digits for this unit, use the **◀ ▶** buttons to move the cursor left and right and use the **▲ ▼** buttons to assign each digit. When the address is complete, press **OK** to exit the field, or press the **Menu** button to cancel.

7. Use the arrow buttons (**▲ ▼ ◀ ▶**) to move the cursor to the **Subnet Mask** field and press **OK** to enter the field.
8. Use the arrow buttons (**▲ ▼ ◀ ▶**) to enter the port's subnet mask. When the address is complete, press **OK** to exit the field.
9. Use the arrow buttons (**▲ ▼ ◀ ▶**) to move the cursor to the **Gateway IP Address** field and press **OK** to enter the field.
10. Use the arrow buttons (**▲ ▼ ◀ ▶**) to enter the port's gateway IP address. When the address is complete, press **OK** to exit the field.

To download the operator guide to a personal computer

IMPORTANT: The Operator Guide PDF file should be downloaded to a personal computer's hard drive. This will ensure that the file is available, even if the unit is not available or offline.

1. Verify that the personal computer is on the same IP subnet as the unit's Control port. For example, on a computer, go to the command prompt, type the following command, and press RETURN:

EXAMPLE: `ping 192.168.0.100` ← Use the IP address assigned to the Control port.

Note: If a message appears similar to "Pinging 192.168.0.100 with 32 bytes of data: Reply from 192.168.0.100: bytes=32 time <1ms TTL=63," the verification is successful. If the ping is unsuccessful, verify that the network configuration is good and repeat the procedure "To set new IP address information" on page 29.

2. To access the unit from a PC, open an Internet Browser window and type the IP address of the Control port.

For example, type `192.168.0.100` and press ENTER. ARRIS recommends using Chrome or Firefox. Do not type www or http.

3. When the Login window appears (shown in Figure 10), leave the Password field blank and select the Login button located at the bottom-right corner.

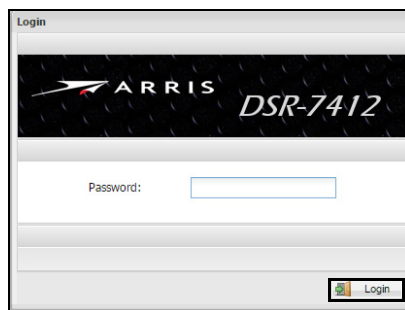

Figure 10: Login Screen

4. When the main window appears, select the Help button and download the Operator Guide PDF to the computer's hard drive. To do this, right-click on the **pdf download** link, as shown in Figure 11 on page 31, and select **Save link as...**
5. When the Directory Window appears, navigate to the desired location on your computer's hard drive (usually the desktop) and select Open.
6. If it is necessary to close the unit's browser window, select the Close button (**X**) in the upper-right corner.

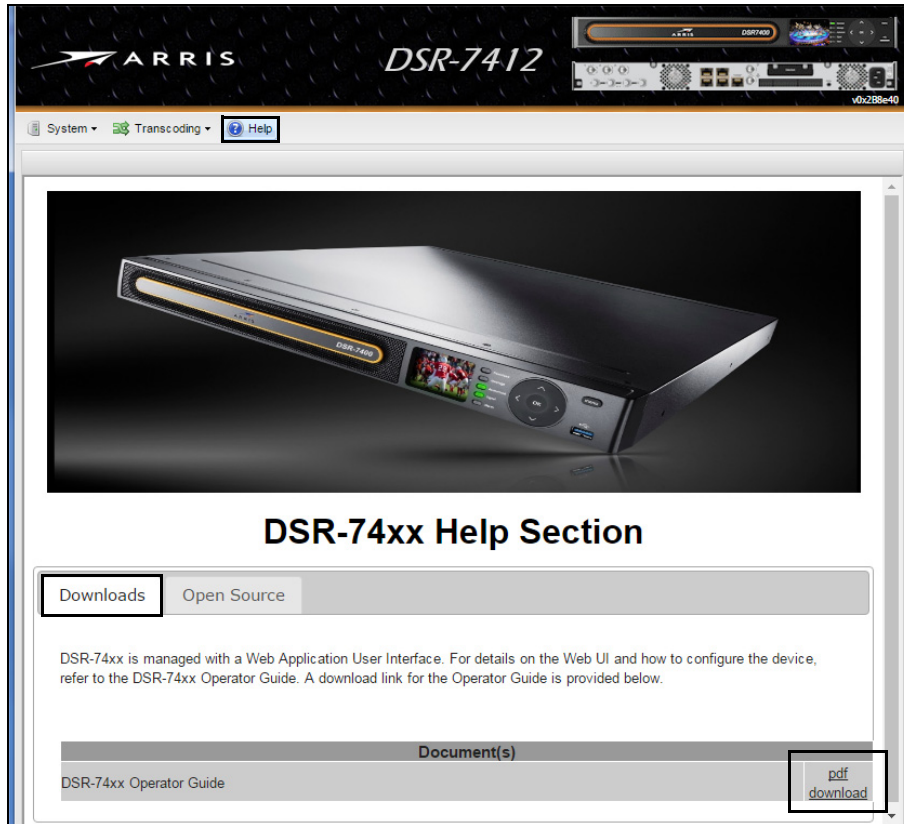

Figure 11: Using the Help Screen to Download the Operator Guide

Automatic RF Port Setup

If the port setup is not defined by the Programmer, the Authorized LED (on the front panel) will be off. If this is the case, the Programmer may ask you to perform the following procedure. This will specify the virtual channel information so the unit will automatically configure the Satellite ID and Polarity parameters and authorize the unit for use.

To define the port setup

1. Go to the Channel Select Submenu (described on page 51) and specify the following two parameters:
 - Virtual Channel Table (specified by the Programmer)
 - Virtual Channel Number (specified by the Programmer)
2. Go to the RF Port Setup Submenu (described on page 50), set the Satellite ID parameter to **000**, and press **OK** to exit the field.
3. Verify that the Satellite ID parameter now displays a value other than **000**.
4. If it is necessary to continue with the installation procedure, continue with step 11 on page 26.

Optional

Configuring Keep Alive for DCII Subtitles

The intent of the Keep Alive function is to ensure that downstream equipment continues to receive DCII subtitle messages (one message every second). Without this capability, some downstream equipment can drop subtitle messages.

To configure Keep Alive for DCII Subtitles

IMPORTANT: This procedure only applies to transcoded output, not pass thru output. Do not perform this procedure if the subtitles are overlaid.

1. Go to the System > Settings menu (shown in Figure 12) and use the mouse to place a checkmark in the Keep Alive checkbox.
2. Use Table 6 to specify the desired Stuffing Format and select Save.

The Programmer cannot override the parameters in this dialog box.

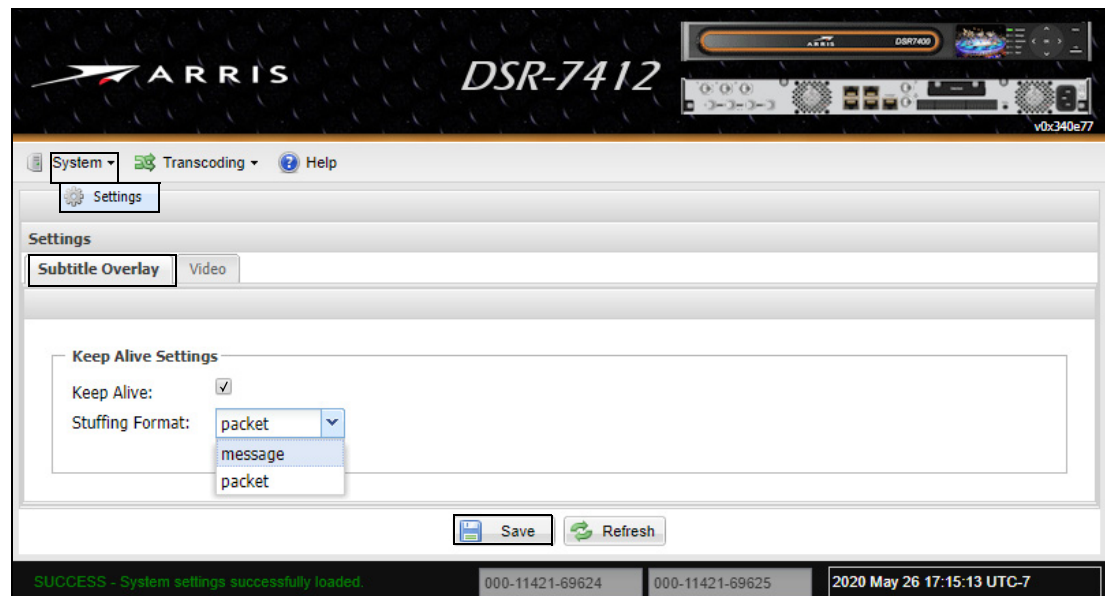

Figure 12: Keep Alive Dialog Box

Table 6: Keep Alive Parameters

Parameter	Description
Keep Alive	Use this checkbox to enable/disable the Keep Alive function.
Stuffing Format	Use this pulldown menu to specify the type of Keep Alives to send to the downstream equipment.
Message	When a subtitle message is not received (in the time frame of one second), the unit generates and sends a DCII stuffing message in its place.
Packet	When a subtitle message is not received (in the time frame of one second), the unit generates and sends an empty transport stream packet message in its place.

Configuring SD Aspect Ratio

Use this screen to specify how the unit applies the aspect ratio to an outgoing transcoded SD video.

To configure the unit's Standard Definition aspect ratio

1. Open an Internet browser window and type the Control port's IP address in the Address box. ARRIS recommends using Chrome or Firefox.

For example, type **192.168.0.100** and press ENTER.
Do not type www or http.

2. When the Login window appears, as shown below, leave the Password field blank and select the Login button that is located at the bottom-right corner.

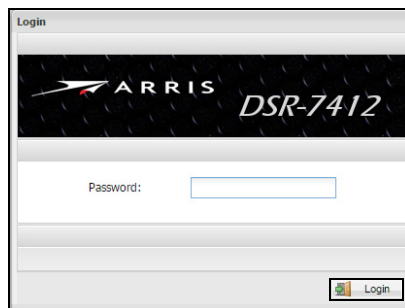

3. When the main window appears, select the System pulldown menu and choose Settings.
4. When the Settings window appears, select the Video tab (as shown below).

The Programmer cannot override this setting.

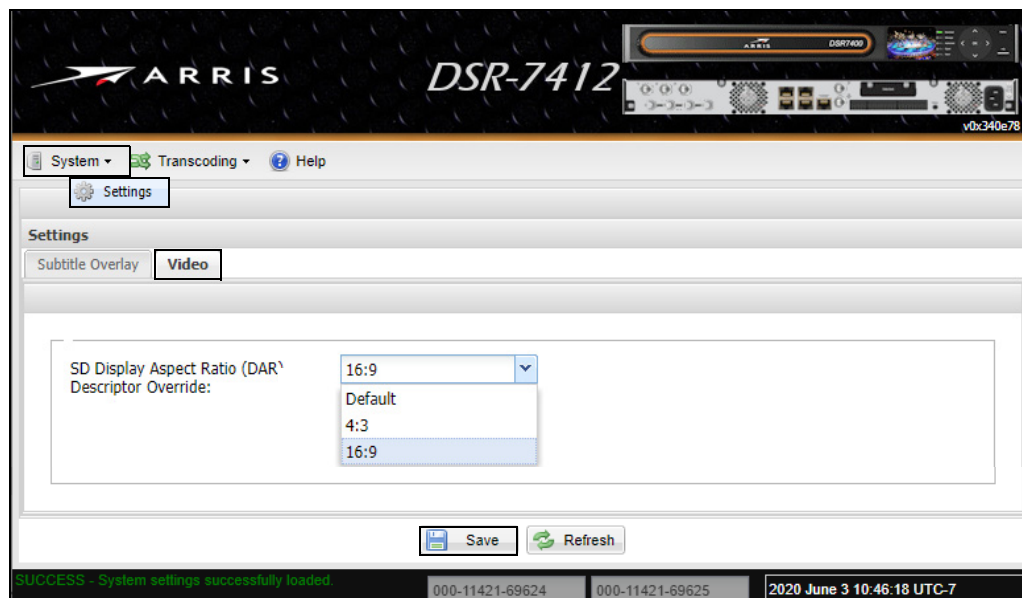

5. Use the pulldown menu to specify the desired ratio.

Note: The Default option applies the setting that is embedded within the incoming stream.

6. Select the Save button to apply and save the new setting.

Front Panel and Back Panel

Front Panel

Figure 13 shows the unit's front panel Liquid-Crystal Display (LCD) and the five Light-Emitting Diodes (LEDs).

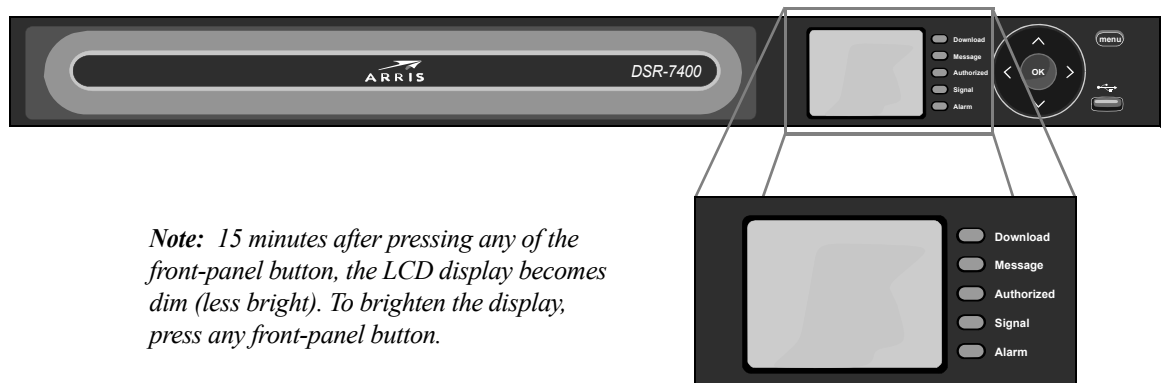

Note: 15 minutes after pressing any of the front-panel button, the LCD display becomes dim (less bright). To brighten the display, press any front-panel button.

Figure 13: Front-Panel LCD and LEDs

Use the following LEDs to interpret the unit's current status:

Download	Blinks green when a firmware download is in progress and illuminates solid green when the unit has successfully received the firmware download and is now waiting for activation by the Programmer. For more details, see parameter description for "Download Status" on page 46.
Message	(This LED is reserved for future use.)
Authorized	Illuminates green when all configured services are authorized. Blinks green when some but not all configured services are authorized.
Signal	Illuminates green when all configured services are acquired. Blinks green when some but not all configured services are acquired.
Alarm	Illuminates red when the unit enters an alarm state. Blinks red if an internal error is present. If the condition persists, contact ARRIS Product Support (described on page 18).

Front-Panel Control Pushbuttons

Figure 14 shows the six front-panel pushbuttons that are used for menu navigation, editing parameters, and displaying video on the LCD screen.

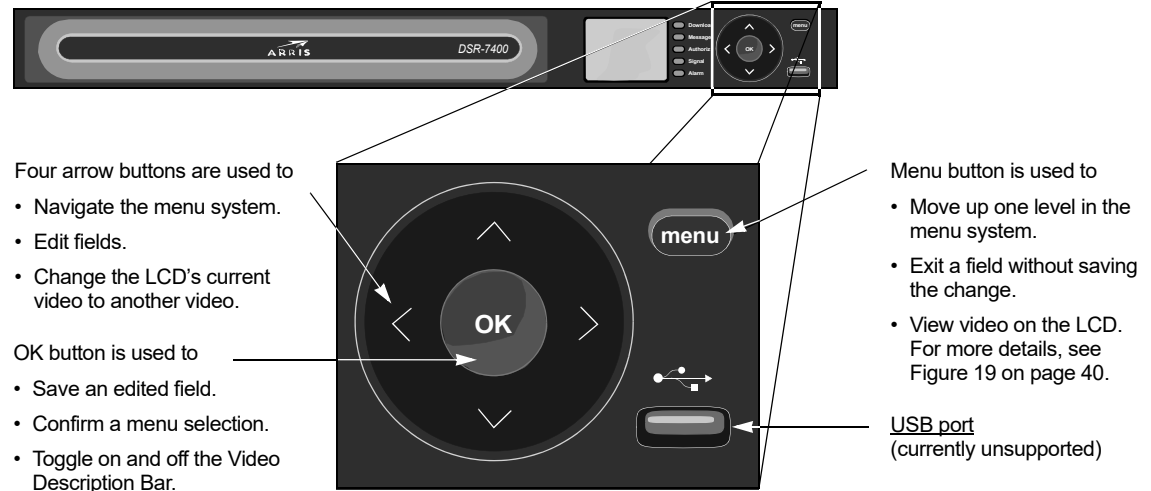

Figure 14: Front-Panel Control Buttons

Back Panel

Figure 15 shows the unit's back panel.

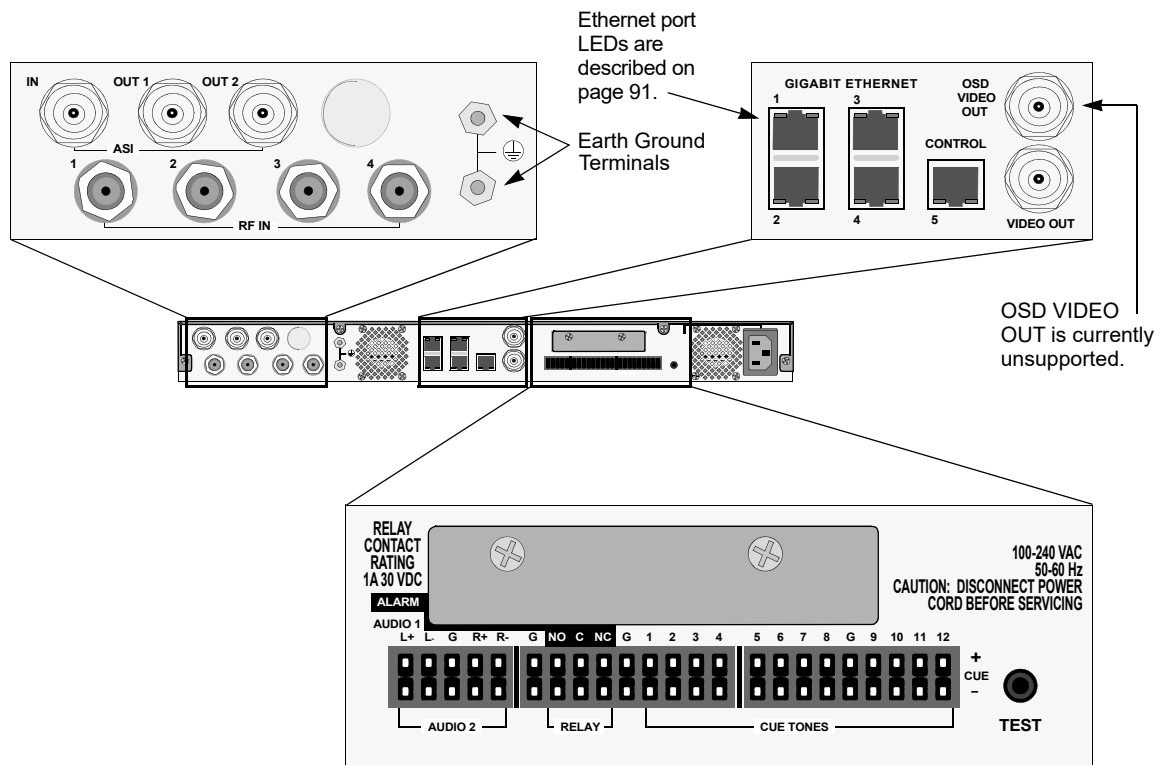

Figure 15: Back Panel

Using the Menu System

When the unit is powered up, the LCD displays an on-screen menu system with the Main Menu as the first screen.

Overview

Visual Indicators

Figure 16 describes various visual indicators within the menu system.

MAIN MENU

- The current menu title appears at the top with black text and orange background.
- A menu item with a black background and white text designates the menu option that is currently highlighted. Either press **OK** to enter the menu or use the arrow buttons (**◀ ▶ ▲ ▼**) to move the highlight to another menu item.
- A triangle on the right of the screen signifies that the menu leads to a submenu.

Quick Install
System
Input
Process
Press OK to select

GENERAL

- Notice the GENERAL menu has three fields and the top-most field is highlighted with a black background and white text.
- An orange box with black text designates a read-only label. For example, the General menu (shown here) has three read-only labels: Model, UA, and S/N. Each label is on the left and the associated information is on the right.
- The Status/Instruction bar (black area at the bottom of the screen) also shows the field name (Model Number). If the operator uses the **▼** button to move to the UA field, the Status/Instruction bar will then display Unit Address.

Model DSR-74XX
Name D74-37
UA 1 000-11420-01681-724
UA 2 000-11420-01682-832
Model Number

RF TUNER

- This is an example of a menu with six parameters. Each parameter has a field that can be edited as needed.
- A gray box with black text designates the field is saved.
- A green box or green outline signifies a properly-configured item. A red box or outline signifies a fault or configuration issue.
- A white box with orange text designates the field is currently being edited. In this example, the operator uses the **▲** and **▼** buttons to choose the desired modulation mode.

Tuner 1 RF Port 1
1130.00 16
DVBS2 32.700
Modulation Mode

Figure 16: Menu System - Visual Indicators (Example)

Navigating the Menu System

The Status/Instruction bar at the bottom of the screen serves three purposes:

- Instructions (white text) assist the operator with helpful tips for operation.
- Parameter name (white text) shows the name of the currently-highlighted parameter.
- Navigation icons (in the bottom right corner) show which of the five front-panel buttons may be used to navigate the menu system.

Figure 17 describes the Status/Instruction bar in more detail.

To navigate the menu system

1. Use the ▲ ▼ buttons to move the highlight up and down.
2. Once the desired menu item is highlighted, press **OK** to enter the menu.
3. If it is necessary to exit the current menu and move to the previous menu, press the **Menu** button.

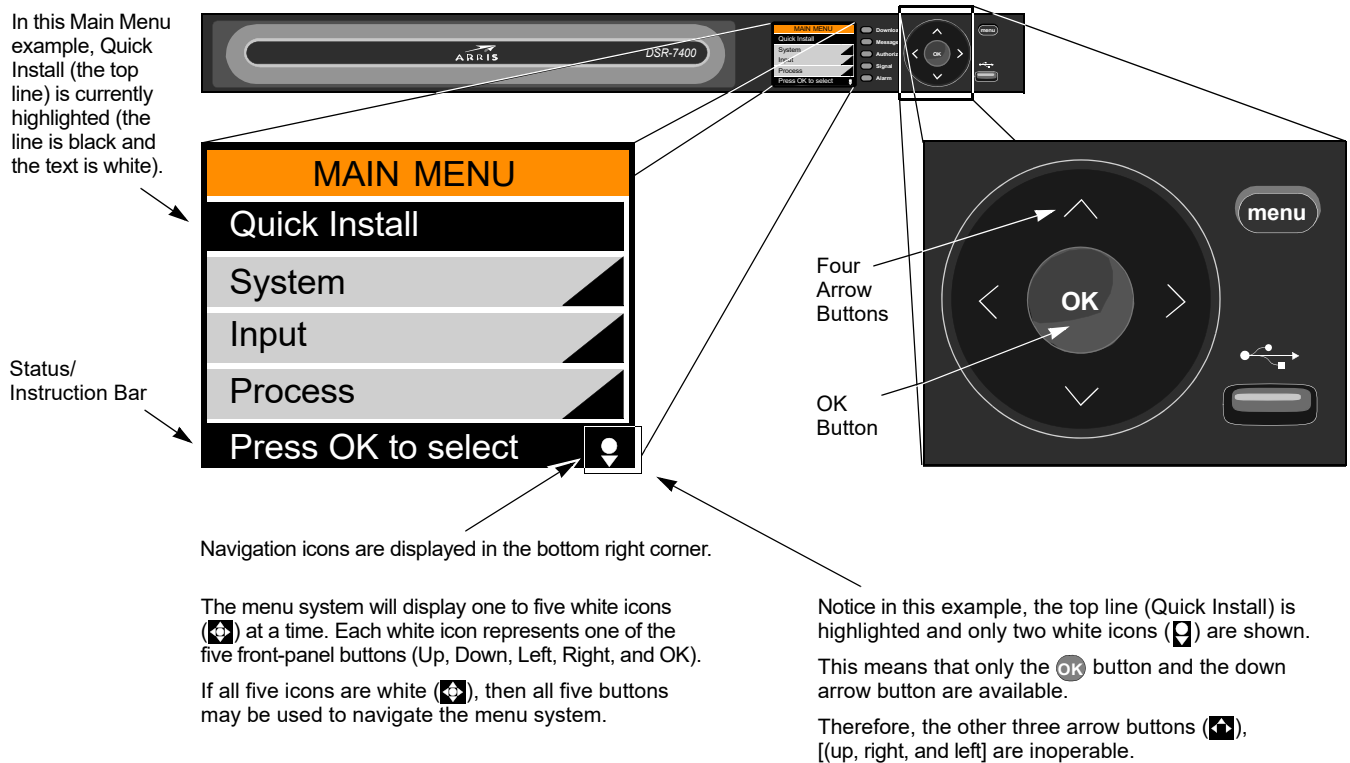

Figure 17: Status/Instruction Bar and Navigation Buttons (Example)

Editing Fields Within the Menu System

To edit a field

1. Navigate to the desired menu.
2. Use the arrow buttons (◀ ▶ ▲ ▼) to navigate to the desired field and press **OK** to enter the field.
3. To specify the desired setting, use the ◀ ▶ buttons to move the cursor left and right and use the ▲ ▼ buttons to choose the desired option or number.
4. When the desired option is specified, press **OK** to save the change and exit the field.

or

If it is necessary to exit the field without saving the change, press **Menu**.

Figure 18 provides more detail on how to edit fields and use the **Menu** button.

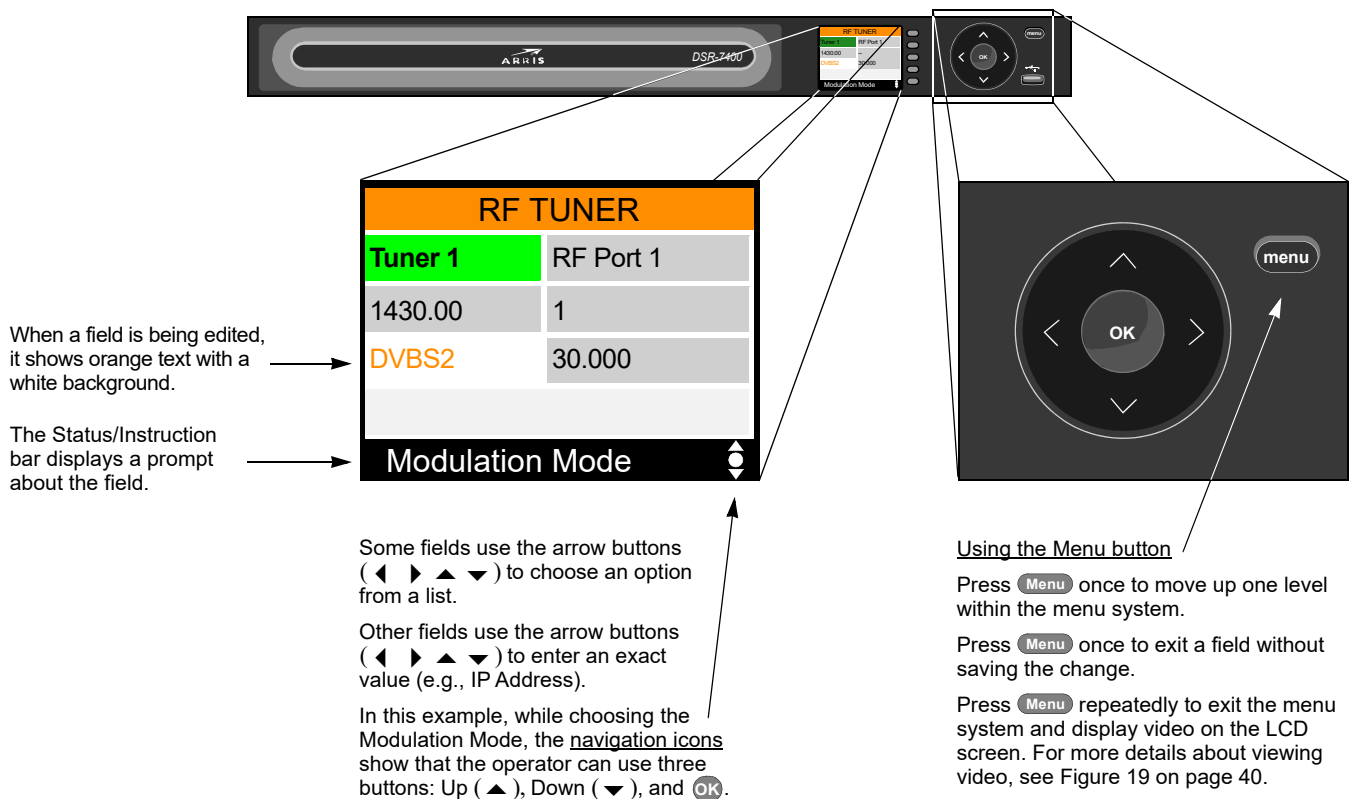

Figure 18: Editing Fields Within the Menu System (Example)

Using the Front-Panel LCD to Monitor Video

Figure 19 describes how to use the front-panel buttons to display video on the LCD screen.

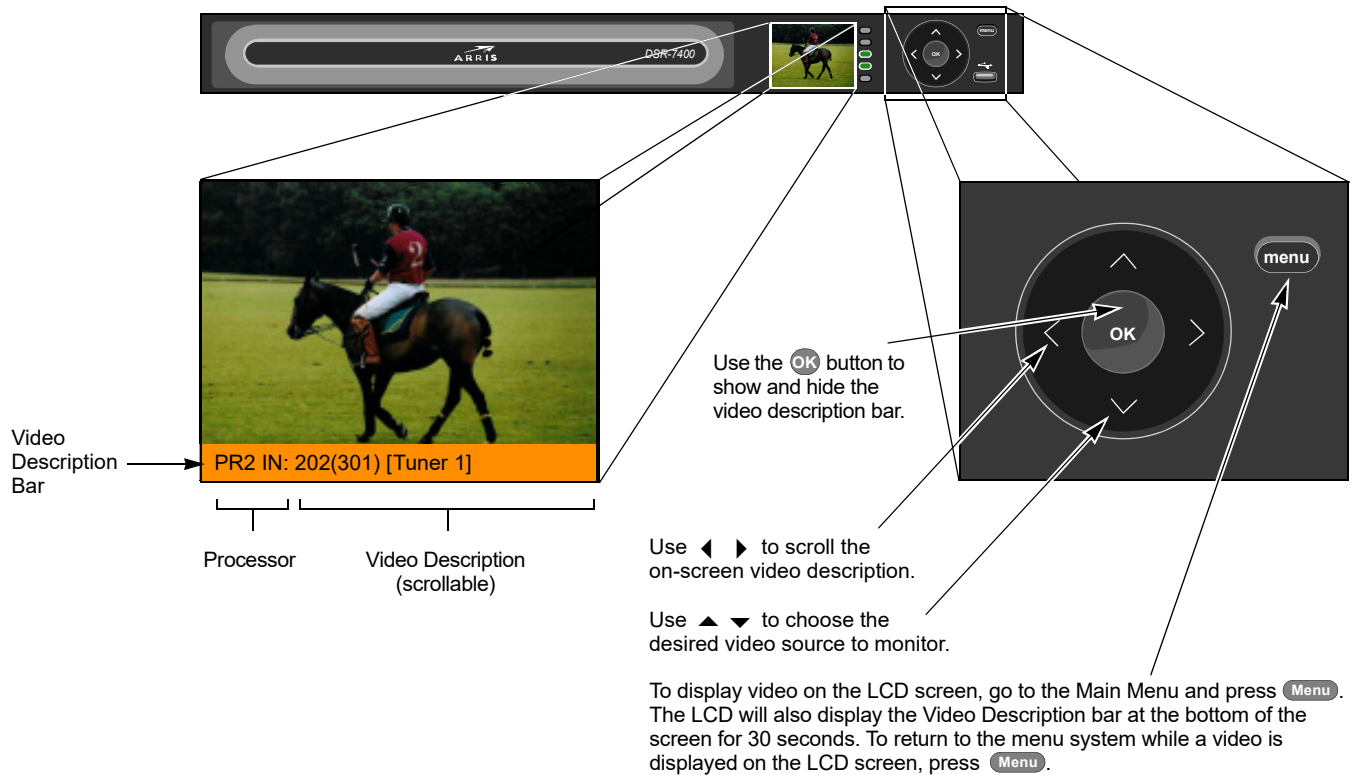
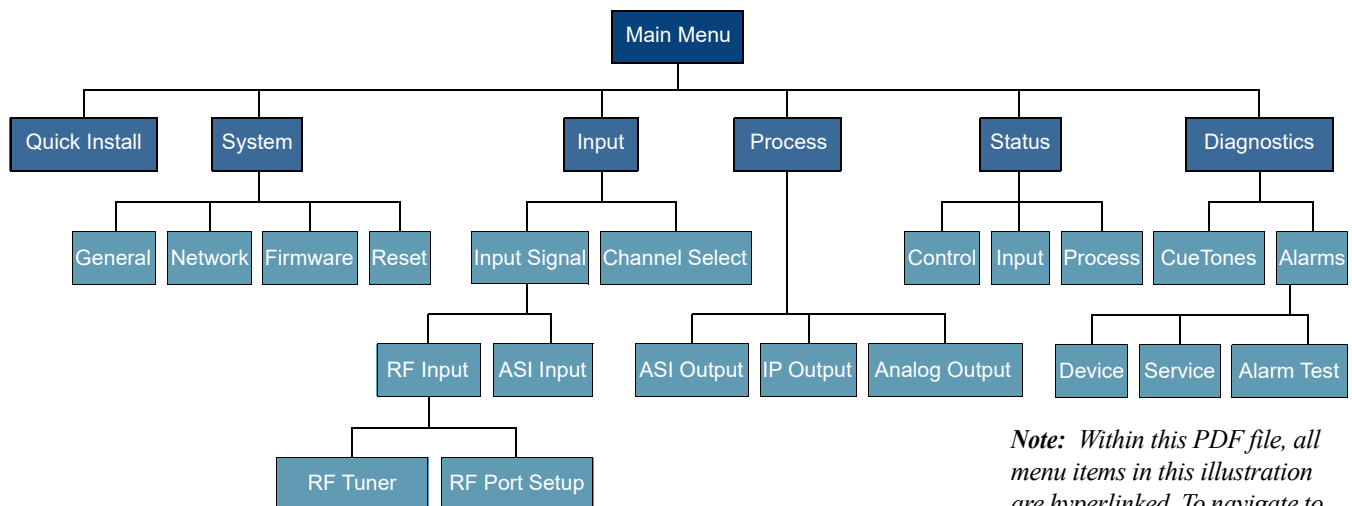

Figure 19: Viewing Video on the LCD

Menu System Hierarchy

Figure 20 shows the hierarchy of all menus and submenus.



Note: Within this PDF file, all menu items in this illustration are hyperlinked. To navigate to a description, use the mouse to click on the menu item.

Figure 20: Menu System Hierarchy

Main Menu

The Main Menu (shown in Figure 21) has six submenus (Quick Install, System, Input, Process, Status, and Diagnostics). Use the ▲ ▼ buttons to scroll down and see the Status and Diagnostics submenus at the bottom of the listing.

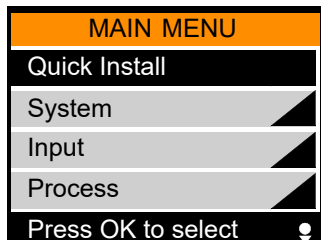

To navigate to this menu:
press **Menu** several times until
the **Main Menu** appears.

Figure 21: Main Menu

Quick Install Menu

The Quick Install menu supports two video distribution schemes:

- Satellite Video Distribution that uses RF input, see Figure 22 (below).
- Content Delivery Network (CDN) Video Delivery that uses HLS input, see Figure 23 on page 42.

Satellite Video Distribution (RF Input)

The Quick Install menu that supports Satellite Video Distribution has seven fields, as shown in Figure 22. The gray box next to the menu shows the name and location of each field. The table on page 42 describes each field.

IMPORTANT: Use this menu to specify one RF port as an input port. If it is necessary to specify more than one RF input port, do not use the Quick Install Menu. See "Channel Select Submenu" on page 51.

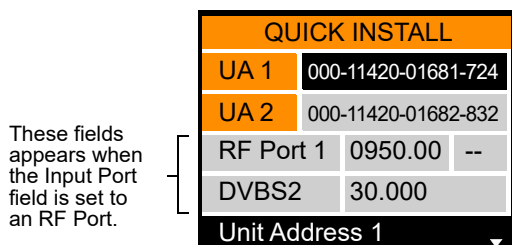

These fields
appears when
the Input Port
field is set to
an RF Port.

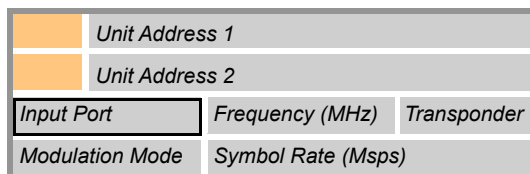

To navigate to this menu:
press **Menu** several times until the **Main Menu**
appears, highlight **Quick Install** and press **OK**.

Figure 22: Quick Install Menu - RF Input

CDN Video Delivery (HLS Input)

The Quick Install menu that supports CDN Video Delivery. This submenu has four fields and one read-only descriptive field, as shown in Figure 23. The gray box next to the menu shows the name and location of each field. The following table describes each parameter. For a full description of CDN distribution, see "Configuring CDN Streaming Services" on page 87.

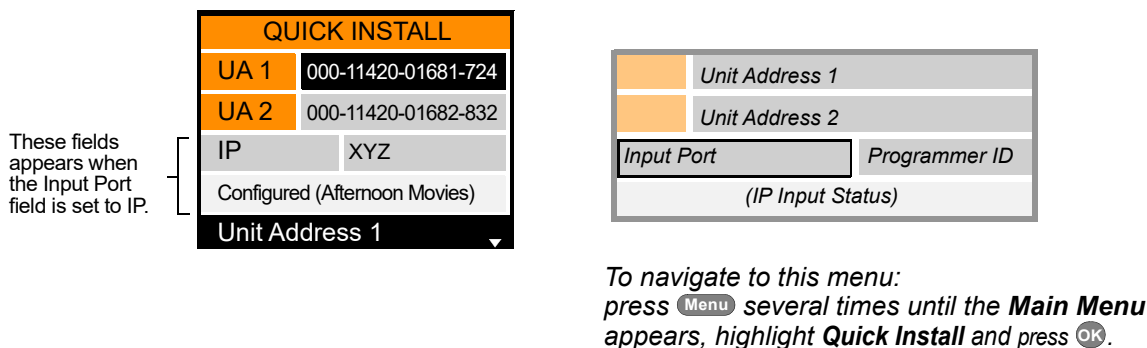
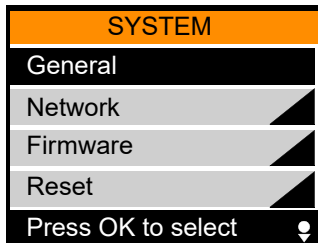

Figure 23: Quick Install Menu - HLS Input

Parameter	Description
Unit Address 1	The two unit addresses are read only. They are unique to the unit and cannot be changed. These two addresses are also printed on the label attached to the bottom of the unit and are displayed in the System > General submenu. In order to authorize the unit, these two addresses must be communicated to the Programmer.
Unit Address 2	
Input Port	Use this parameter to specify the desired input port. Choose either RF input port (RF Port 1 or RF port 2), IP (HLS input), or Disabled (default). Once the input is specified, evaluate the other parameters to view and/or change those aspects of the input port. If Disabled is specified, the tuner is not configured.
Frequency (MHz)	Use this parameter to view/specify the input signal frequency for the currently specified Input Port (described above).
Transponder	Use this parameter to view and/or set the desired transponder value (1 to 24).
Modulation Mode	Use this parameter to view/specify the desired Modulation Mode for the specified Input Port (described above). Choose the desired option: DVBS2, DCII, DVBS2x, or 8PSK-TC.
Symbol Rate (Mps)	Use this parameter to view/specify the desired symbol rate value (3 to 35).
Programmer ID	Use this parameter to view/specify the desired programmer. If you are unsure of the Programmer ID, please contact your Programmer.
IP Input Status	This read-only field displays the status for the IP input. For specific details, see "Troubleshooting CDN Connectivity/Configuration Issues" on page 90.

System Menu

The System menu, as shown in Figure 24, has four submenus (General, Network, Firmware, and Reset).



To navigate to this menu:
press **Menu** several times until the **Main Menu** appears, highlight **System**, and press **OK**.

Figure 24: System Menu

General Submenu

The General submenu, as shown in Figure 25, has five read-only fields (Model Number, Name, Unit Address 1, Unit Address 2, and Serial Number). The gray box next to the menu shows the name and location of each field. The following table describes each field.

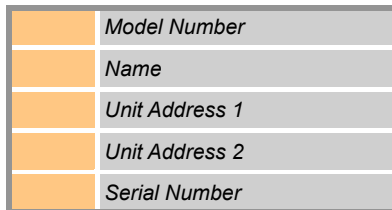
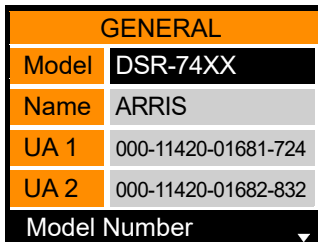

To navigate to this menu:
press **Menu** several times until the **Main Menu** appears, highlight **System**, press **OK**, highlight **General**, and press **OK**.

Figure 25: General Submenu

Field	Description
Model Number	This field displays the unit's model number (either DSR-7403, DSR-7406, or DSR-7412). This field is read only and cannot be edited.
Name	This field displays the unit's name that was assigned by the Programmer. This read only field is for future use and cannot be edited.
Unit Address 1 (and CRC)	The two unit addresses (UA 1 and UA2) are read only. These addresses are unique to the unit and cannot be changed. After the 13-digit unit address is a 3-digit Cyclic Redundancy Code (CRC). These two addresses are also printed on the label attached to the bottom of the unit and are also displayed in the System > Quick Install submenu. In order to authorize the unit, the two unit addresses must be communicated to the Programmer.
Unit Address 2 (and CRC)	
Serial Number	This field displays the unit's factory-assigned serial number. This field is read only and cannot be edited.

Network Submenu

The Network submenu, as shown in Figure 26, has 13 parameters. The gray box next to the menu shows the name and location of each field. The following table describes each parameter.

IMPORTANT: If your site is using CDN Video Delivery, ARRIS recommends using a DHCP server to auto-fill these fields: IP Address, Subnet Mask, Gateway IP Address, DNS Server IP Address(es), and NTP Server IP Address(es). For more details, see "Configuring CDN Streaming Services" on page 87.

NETWORK	
Ethernet 1	DHCP
162.168.1.100	255.255.255.000
162.168.1.1	
10-05-b1-f8-a0-1a	1000 Mbps
Ethernet Port	

Ethernet Port	Host Config
IP Address	Subnet Mask
Gateway IP Address	(not used)
MAC Address	Line Rate
DNS Config	(not used)
DNS Server 1	DNS Server 2
NTP Config	(not used)
NTP Server 1	NTP Server 2

To navigate to this menu: press **Menu** several times until the **Main Menu** appears, highlight **System**, press **OK**, highlight **Network**, and press **OK**.

Figure 26: Network Submenu

Parameter	Description
Ethernet Port	Use this parameter to configure the Ethernet ports located on the back panel. IMPORTANT: The following is a description of each port's intended purpose: <i>Ethernet 1</i> <i>Content Input</i> <i>Ethernet 2</i> <i>Content Input</i> <i>Ethernet 3</i> <i>Content Output</i> <i>Ethernet 4</i> <i>Content Output</i> <i>Control</i> <i>Used to access the unit's Web GUI and to download the Operator Guide (this document).</i>
Host Config	Use this parameter to specify how the port's IP address information will be set. Use the up and down arrow buttons (▲ ▼) to choose the desired option: Static Use this option to set the port's IP address information manually, using the front-panel arrow buttons. This is the default for the Control port and Ethernet Ports 2, 3, and 4. DHCP Use this option to have the DHCP server to set the port's IP address information automatically. This is the default for Ethernet Port 1.
IP Address	Use this parameter to view and change the IP address of the Ethernet Port (the Ethernet Port parameter [described above]). IMPORTANT: Each of the five Ethernet ports must have a unique subnet. Contact your site's network administrator for details about configuring Ethernet ports for operation on your local network.
Subnet Mask	Use this parameter to view and change the Subnet Mask for the specified Ethernet Port (the Ethernet Port parameter [described above]).
Gateway IP Address	Use this parameter to view and change the Gateway IP Address for the Ethernet Port (the Ethernet Port parameter [described above]).

If the Host Config parameter is set to DHCP, these three parameters cannot be edited.

Parameter	Description
MAC Address	Use this parameter to view the unit's unique MAC Address for the Ethernet Port (the Ethernet Port parameter [described above]). The MAC address is represented in hexadecimal format. It is read only and cannot be edited.
Line Rate	Use this parameter to view the operating line rate (10, 100, or 1000) that is associated with the specified Ethernet Port (the Ethernet Port parameter [described above]). The value is shown in Mbps. This field is read only and cannot be edited.
DNS Config Config	Use this parameter to specify how the port's DNS server IP addresses (DNS Server 1 and DNS Server 2) will be specified. Use the front-panel arrow buttons to choose the desired option: Manual Use this option to set the DNS server IP addresses manually. This is the default setting for the Control port and Ethernet Ports 2, 3, and 4. Auto Use this option to have the DHCP server set the DNS server IP addresses automatically. This is the default setting for Ethernet Port 1.
DNS Server 1	If the DNC Config parameter (described above) is set to Manual, use the front-panel arrow buttons to set the desired IP address(es). If the DNC Config parameter is set to Auto, do not set the DNS Server IP address(es) because the IP addresses are set automatically by the DHCP server.
DNS Server 2	If the address(es) are being entered manually (using the front-panel buttons), observe the following guidelines: <ul style="list-style-type: none"> • If only one Domain Name Server (DNS) is being used, enter the server's IP address in the DNS Server 1 field. • If a second DNS server is being used, enter the server's IP address in the DNS Server 2 field.
NTP Config	Use this parameter to specify how the port's NTP server IP addresses (NTP Server 1 and NTP Server2) will be specified. Use the front-panel arrow buttons to choose the desired option: Manual Use this option to set the NTP server IP addresses manually. This is the default setting for the Control port and Ethernet Ports 2, 3, and 4. Auto Use this option to have the DHCP server set the NTP server IP addresses automatically. This is the default setting for Ethernet Port 1.
NTP Server 1	If the NTP Config parameter (described above) is set to Manual, use the front-panel arrow buttons to set the desired IP address(es). If the NTP Config parameter is set to Auto, do not set the NTP Server IP address(es) because the IP addresses are set automatically by the DHCP server.
NTP Server 2	If the address(es) are being entered manually (using the front-panel buttons), observe the following guidelines: <ul style="list-style-type: none"> • If only one NTP Server is being used, enter the server's IP address in the NTP Server 1 field. • If a second NTP server is being used, enter the server's IP address in the NTP Server 2 field.

For a better understanding of how these same fields work within the Web GUI, see Figure 51 on page 64

Firmware Submenu

The Firmware submenu always displays two or more read-only fields, as shown in Figure 27. The gray box next to the menu shows the name and location of each field. The following table describes each parameter.

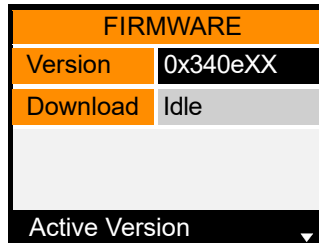

To navigate to this menu: press **Menu** several times until the **Main Menu** appears, highlight **System**, press **OK**, highlight **Firmware**, and press **OK**.

Figure 27: Firmware Submenu

Parameter	Description	
Active Version	Use this parameter to view the unit's current firmware version number. This read-only value cannot be edited. This document describes Firmware Version 0x340eXX.	
Download Status	Idle	Designates that no code download is present. During the idle state, the front-panel Download LED is off.
	Receiving	Designates that the unit is in the process of receiving a code download. During this process, the front-panel Download LED blinks green.
	Waiting	Designates that the unit has received the entire code download and is waiting to be activated. At this point, the front-panel Download LED stops blinking and displays solid green.
DL Version	This field only displays when the unit is receiving or waiting to activate a code download file. The value shown here is the firmware version number associated with the code download file. This read-only value cannot be edited.	
Act Date (UTC)	This field displays the scheduled date that this code download will be activated.	<i>Note:</i> When the scheduled activation date and time is reached, the unit will automatically activate the code download file. If the date and time in these two fields are in the past, the unit will immediately activate the code download. Once the new code download is activated, the unit cannot be reverted to the previously-loaded code.
Act Time (UTC)	This field displays the scheduled time that this code download will be activated.	
File 1 (Received)	This field will only display when the unit is receiving or waiting to activate a code download file. This value designates the number of segments that have been received up to this point.	
	If a code download requires multiple file segments, this menu will list all of the download files in numerical order (for example, File 1, File 2, File 3, etc). Each download file is followed by two fields (Total and Current, described below).	
(Total)	This value designates the total number of file segments within the file.	
(Current)	This value designates which segment (number) is currently being received. It is important to remember that segments may not always be received in numerical order.	

These six fields only appear in the menu if the Download Status field displays either **Receiving** or **Waiting**.

Once the code download is activated, these fields are removed from the menu and only Version and Download appear in the menu, as shown in Figure 27.

Reset Submenu

The Reset submenu has four options, as shown in Figure 28. To perform one of these options, navigate to the Reset submenu, press the **OK** button to enter the submenu, use the up and down arrow buttons (**▲ ▼**) to choose the desired reset option, and press **OK** to initiate the reset. The following table describes each reset option.



To navigate to this menu:

press **Menu** several times until the **Main Menu** appears, highlight **System**, press **OK**, highlight **Reset**, and press **OK**.

Figure 28: Reset Submenu

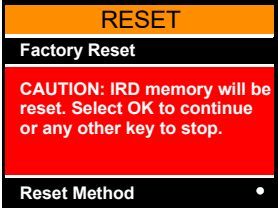
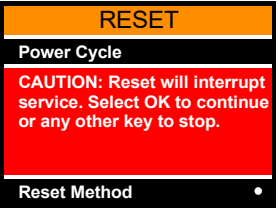
Reset Option	Description
No Reset	The No Reset designation is the default setting that is displayed automatically. Use the up and down arrow buttons (▲ ▼) to choose one of the following three reset options or press ENTER to exit this submenu.
Reset (Keep IP)	Use the Reset (Keep IP) option to perform a factory reset and maintain all IP address information. When performing this option, a prompt similar to the Factory Reset prompt (shown below) will appear.
Factory Reset	<p>Use the Factory Reset option to reset the system to the programming values originally set by the factory firmware. When performing a Factory Reset, the following prompt appears.</p> <div style="display: flex; align-items: center;"> <div style="flex: 1;"> <p>CAUTION: This operation interrupts service output, so use it carefully.</p> </div> <div style="flex: 1; text-align: center;">  </div> </div> <p>CAUTION: Selecting the Factory Reset option will delete configuration information and all defined setups (including the unit's IP address, gateway, and subnet information). If it is necessary to maintain the unit's IP address information, do not perform a Factory Reset. Instead, choose the Reset (Keep IP) option.</p>
Power Cycle	<p>Use the Power Cycle option to reboot the unit without losing configuration information of IP address information. When performing a Power Cycle, the following prompt appears.</p> <div style="display: flex; align-items: center;"> <div style="flex: 1;"> <p>CAUTION: This operation interrupts service output, so use it carefully.</p> </div> <div style="flex: 1; text-align: center;">  </div> </div>

Input Menu

The Input menu has two submenus (Input Signal and Channel Select), as shown in Figure 29.

IMPORTANT: To configure IP input, do not use the front-panel menu system. Instead, use the web GUI and see "Input Section - ASI Inputs, RF Inputs, and Tuners" on page 72.

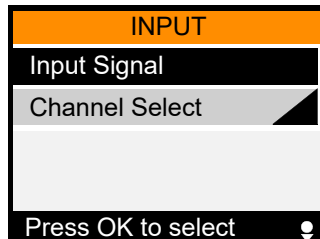

To navigate to this menu:
press the **Menu** button until the **Main Menu** appears, highlight **Input**, and press **OK**.

Figure 29: Input Menu

Input Signal Submenu

The Input Signal submenu, has two submenus (RF Input and ASI Input), as shown in Figure 30.

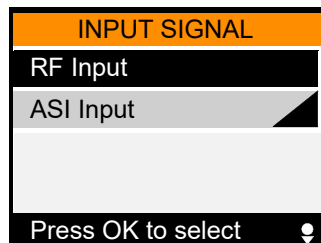

To navigate to this menu:
press the **Menu** button until the **Main Menu** appears, highlight **Input**, press **OK**, highlight **Input Signal**, and press **OK**.

Figure 30: Input Signal Submenu

RF Input Submenu

The RF Input submenu has two submenus (RF Tuner and RF Port Setup), as shown in Figure 31.

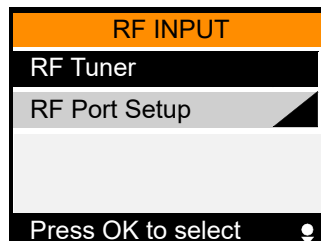

To navigate to this menu:
press the **Menu** button until the **Main Menu** appears, highlight **Input**, press **OK**, highlight **Input Signal**, press **OK**, highlight **RF Input**, and press **OK**.

Figure 31: RF Input Submenu

RF Tuner Submenu

The RF Tuner submenu has six fields, as shown in Figure 32. The gray box next to the menu shows the name and location of each parameter. The following table describes each parameter.

CAUTION: RF Tuning may interrupt service output, so use it carefully.

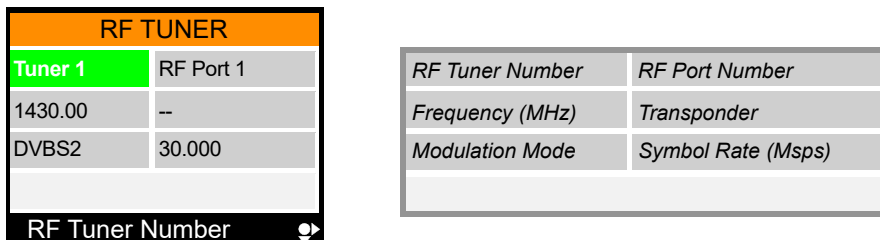

To navigate to this menu:
 press the **Menu** button until the **Main Menu** appears, highlight **Input**, press **OK**, highlight **Input Signal**, press **OK**, highlight **RF Input**, press **OK**, highlight **RF Tuner**, and press **OK**.

Figure 32: RF Tuner Submenu

Parameter	Description
RF Tuner Number	Use this parameter to specify the desired input RF Tuner Number (Tuner 1 to Tuner 4). Once the input is specified, evaluate the other parameters (listed below) to view and/or change.
RF Port Number	Use this parameter to view and/or set the desired input port (RF Port 1 to RF Port 4). If Disabled is specified, the tuner is not configured.
Frequency (MHz)	Use this parameter to view or modify the input signal frequency.
Transponder	Use this parameter to view and/or set the desired transponder value (1 to 24).
Modulation Mode	Use this parameter to view and/or set the desired Modulation Mode. This version (0x340eXX) supports DVBS2, DCII, DVBS2x, and 8PSK-TC.
Symbol Rate (Mpsps)	Use this parameter to specify the desired symbol rate value (3.000 to 35.000).

RF Port Setup Submenu

The RF Port Setup submenu has five parameters, as shown in Figure 33. The following table describes each parameter. The gray box to right of the menu shows the name and location of each field.

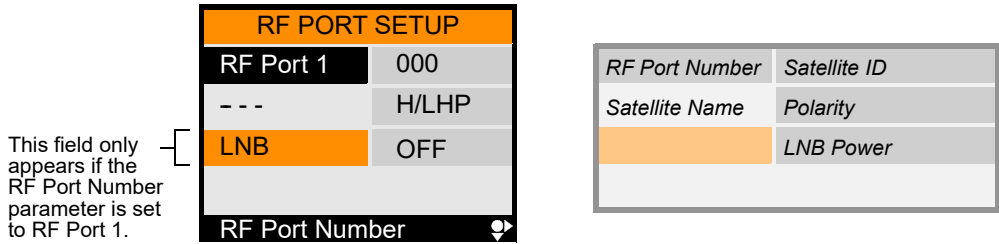

To navigate to this menu:
 press the **Menu** button until the **Main Menu** appears, highlight **Input**,
 press **OK**, highlight **Input Signal**, press **OK**, highlight **RF Input**,
 press **OK**, highlight **RF Port Setup**, and press **OK**.

Figure 33: RF Port Setup Submenu

Parameter	Description
RF Port Number	Use this parameter to choose the desired RF port number (RF Port 1 to RF Port 4).
Satellite ID	Use this parameter to view the Satellite ID of the satellite, if any, connected to the chosen RF port number. This parameter may be set by the Programmer or automatically (see "Automatic RF Port Setup" on page 31). For more instructions, contact your Programmer.
Satellite Name	Use this parameter to view the satellite name of the specified Satellite ID (described above).
Polarity	Use this parameter to view/specify the transponder's current downlink signal polarity for the chosen RF Port Number (specified above). This parameter is set by the Programmer and only applies to Tuner inputs. For specific instructions, consult your Programmer. If specified manually, choose the desired option: H/LHP Designates Horizontal or Left-hand (Circular) polarized. V/RHP Designates Vertical or Right-hand (Circular) polarized. This parameter may be set by the Programmer or automatically (see "Automatic RF Port Setup" on page 31). For more instructions, contact your Programmer.
LNB Power	Use this parameter to enable or disable power to the Low Noise Block (LNB) associated with RF Port 1 (specified above). When this parameter is set to ON, LNB power (18 VDC) is supplied only to RF Port 1. If this parameter is set to OFF, power is not supplied to RF Port 1. This parameter can only be set from the front panel. This parameter is not set by the Programmer.

This field only appears if the RF Port Number parameter is set to RF Port 1.

ASI Input Submenu

The ASI Input submenu has one read-only field and three editable parameters, as shown in Figure 34. The gray box next to the menu shows the name and location of each field. The following table describes each parameter.

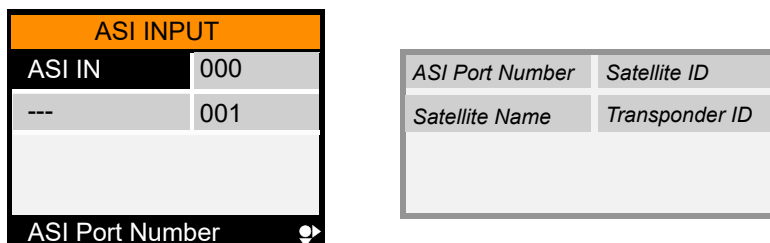

To navigate to this menu:
 press the **Menu** button until the **Main Menu** appears,
 highlight **Input**, press **OK**, highlight **Input Signal**,
 press **OK**, highlight **ASI Input**, and press **OK**.

Figure 34: ASI Input Submenu

Parameter	Description
ASI Port Number (read only)	This read-only parameter always displays ASI IN and relates to the ASI In port on the back panel.
Satellite ID	Use this parameter to view and/or set the Satellite ID of the satellite, if any, associated with the ASI input port. This is used for virtual channel tuning.
Transponder ID	Use this parameter to view and/or set the Transponder number of the transponder, if any, associated with the ASI input port. This is used for virtual channel tuning.
Satellite Name	Use this parameter to view and/or specify the satellite name.

Channel Select Submenu

The Channel Select submenu has six fields, as shown in Figure 35. These fields are typically configured by the uplink. The gray box next to the menu shows the name and location of each field. The table on the next page describes each parameter.

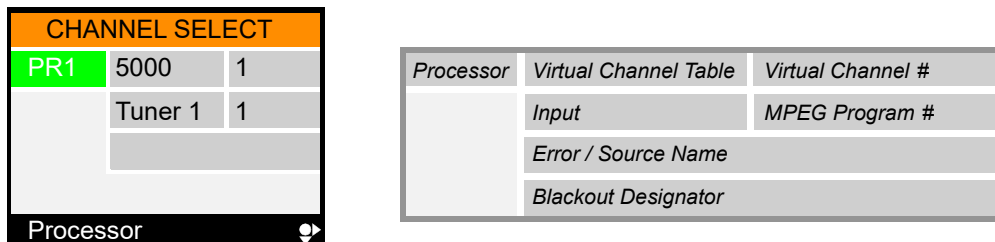

To navigate to this menu:
 press the **Menu** button until the **Main Menu**
 appears, highlight **Input**, press **OK**, highlight
Channel Select, and press **OK**.

Figure 35: Channel Select Menu

Parameter	Description
Processor	Each processor transcodes a single input service according to its own unique configuration settings. Once the Processor is specified, evaluate the following parameters and make changes as needed.
Virtual Channel Table	Use this parameter to choose the Virtual Channel Table (VCT) number (0 to 65535).
Virtual Channel Number	Use this parameter to choose the Virtual Channel Number (VCN). Supported values are 0 to 4095.
Input	Use this parameter to choose the desired input (choose Tuner 1, Tuner 2, Tuner 3, Tuner 4, ASI IN, or IP IN).
MPEG Program Number	If VCT/VCN is not specified by the Programmer (as described above), it may be necessary to use this field to specify the MPEG program number(s).
Error / Source Name (read only)	This field displays the program source name. If the program source name is not defined, an error message will be displayed.
Blackout Designator	This field displays Blackout if the program is currently unavailable.

For Virtual Channel selection, set these two fields.

For MPEG selection, set these two fields.

Process Menu

The Process menu has three submenus (ASI Output, IP Output, and Analog Output), as shown in Figure 36.

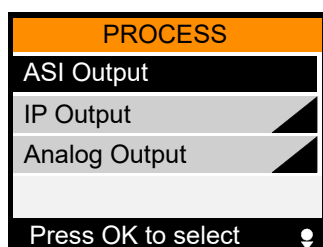

To navigate to this menu: press the **Menu** button until the **Main Menu** appears, highlight **Process**, and press **OK**.

Figure 36: Process Menu

ASI Output Submenu

The ASI Output submenu displays the output multiplex assigned to each ASI output port (ASI-1 and ASI-2) as shown in Figure 37. The gray box next to the menu shows the name and location of each field. The following table describes each parameter.

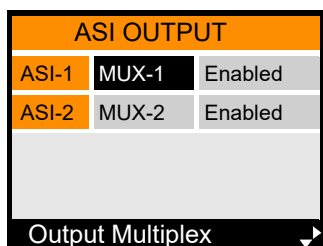

	Output Multiplex	Output Status
	Output Multiplex	Output Status

To navigate to this menu: press the **Menu** button until the **Main Menu** appears, highlight **Process**, press **OK**, highlight **ASI Output**, and press **OK**.

Figure 37: ASI Output Submenu

Parameter	Description
Output Multiplex (read only)	This field displays the multiplex that is currently assigned to the ASI output port. This parameter is configured by the Programmer and cannot be changed using the decoder's front panel.
Output Status (read only)	This field displays the status (Enabled or Disabled) of the ASI output port. This read-only parameter is configured by the Programmer and cannot be changed using the decoder's front panel.

IP Output Submenu

The IP Output submenu (shown in Figure 38) displays the IP outputs assigned to each output multiplex. The gray box next to the menu shows the name and location of each field. The following table describes each parameter.

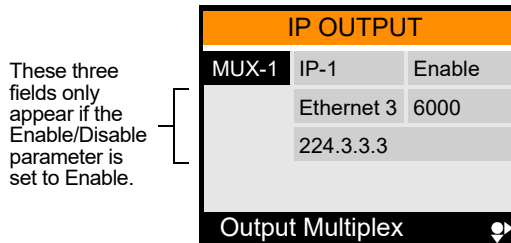

These three fields only appear if the Enable/Disable parameter is set to Enable.

Output Multiplex	Output	Enable/Disable
	Ethernet Port	UDP Port
	IP Address	

To navigate to this menu: press the **Menu** button until the **Main Menu** appears, highlight **Process**, press **OK**, highlight **IP Output**, and press **OK**.

Figure 38: IP Output Submenu

Parameter	Description
Output Multiplex	Use this field to choose a desired output multiplex.
Output	Use this field to choose the desired IP output (either IP-1 [primary] or IP-2 [backup]) for the selected Output Multiplex (described above).
Enable/Disable	Use this field to Enable or Disable the IP output.
Ethernet Port	Use this field to choose the desired Ethernet port for the IP output.
UDP Port	Use this field to specify the destination UDP port used for the IP output.
IP Address	Use this field to specify the destination multicast IP address for the IP output.

These three fields only appear if the Enable/Disable parameter is set to Enable.

Analog Output Submenu

The Analog Output submenu (shown in Figure 39) has 11 fields. Use this submenu to configure the signal for the Video Out port located on the back panel. The gray box next to the menu shows the name and location of each field. The table on page 54 describes each parameter.

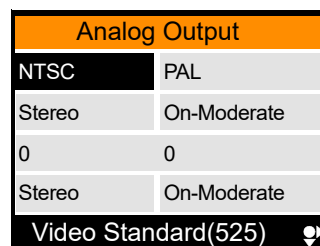

Video Standard(525)	Video Standard(625)
Audio 1 Mix	Audio 1 DialN-Comp
Audio 1 Gain L	Audio 1 Gain R
Audio 2 Mix	Audio 2 DialN-Comp
Audio 2 Gain L	Audio 2 Gain R
SD Default AR	(not used)

To navigate to this menu: press the **Menu** button until the **Main Menu** appears, highlight **Process**, press **OK**, highlight **Analog Output**, and press **OK**.

Figure 39: Analog Output Submenu

Parameter	Description								
Video Standard(525)	Use this parameter to specify output format for 525-line video. Choose either NTSC or PAL-M.								
Video Standard(625)	Use this parameter to specify output format for 625-line video. Choose either PAL or PAL-N.								
Audio 1 Mix and Audio 2 Mix	<p>IMPORTANT: <i>If the audio input mode is stereo and it is connecting to a mono modulator, this field must be set to Mono.</i></p> <p>Use this parameter to choose the desired audio processing option. Choose one of the following:</p> <table> <tr> <td>Stereo</td> <td>Stereo output on both left and right channel (default)</td> </tr> <tr> <td>Dual Mono</td> <td>Mono output on both left and right channels</td> </tr> <tr> <td>Mono</td> <td>Mono output on left channel</td> </tr> <tr> <td>Surround</td> <td>Enhanced stereo with surround pass-through</td> </tr> </table>	Stereo	Stereo output on both left and right channel (default)	Dual Mono	Mono output on both left and right channels	Mono	Mono output on left channel	Surround	Enhanced stereo with surround pass-through
Stereo	Stereo output on both left and right channel (default)								
Dual Mono	Mono output on both left and right channels								
Mono	Mono output on left channel								
Surround	Enhanced stereo with surround pass-through								
Audio 1 DialN-Comp and Audio 2 DialN-Comp	<p>Use this parameter to enable/disable dialog normalization and specify the degree of audio level compression for decoded output. Choose one of the following:</p> <table> <tr> <td>Off-Off</td> <td>DialNorm is not enabled and compression is not enabled.</td> </tr> <tr> <td>On-Heavy</td> <td>DialNorm is enabled and compression is set to reduce the louder audio signals and boost the softer signals using tighter compression thresholds in order to eliminate dramatic fluctuations in the audio signal level and suppress dynamic range of the audio signal.</td> </tr> <tr> <td>On-Moderate</td> <td>DialNorm is enabled and compression is set to reduce or amplify the audio signal, but the thresholds are wider apart, providing moderate dynamic range of the audio signal.</td> </tr> <tr> <td>On-Off</td> <td>DialNorm is enabled and compression is not enabled.</td> </tr> </table>	Off-Off	DialNorm is not enabled and compression is not enabled.	On-Heavy	DialNorm is enabled and compression is set to reduce the louder audio signals and boost the softer signals using tighter compression thresholds in order to eliminate dramatic fluctuations in the audio signal level and suppress dynamic range of the audio signal.	On-Moderate	DialNorm is enabled and compression is set to reduce or amplify the audio signal, but the thresholds are wider apart, providing moderate dynamic range of the audio signal.	On-Off	DialNorm is enabled and compression is not enabled.
Off-Off	DialNorm is not enabled and compression is not enabled.								
On-Heavy	DialNorm is enabled and compression is set to reduce the louder audio signals and boost the softer signals using tighter compression thresholds in order to eliminate dramatic fluctuations in the audio signal level and suppress dynamic range of the audio signal.								
On-Moderate	DialNorm is enabled and compression is set to reduce or amplify the audio signal, but the thresholds are wider apart, providing moderate dynamic range of the audio signal.								
On-Off	DialNorm is enabled and compression is not enabled.								
Audio 1 Gain L and Audio 2 Gain L	Use this parameter to adjust the output level for the Left audio signal. Use the arrow buttons to specify a value from +00 to -20 dB, in 1 dB increments.								
Audio 1 Gain R and Audio 2 Gain R	Use this parameter to adjust the output level for the Right audio signal. Use the arrow buttons to specify a value from +00 to -20 dB, in 1 dB increments.								
SD Default AR	Use this parameter to specify Standard Default Aspect Ratio. Choose either 16:9 or 4:3.								

Status Submenu

The Status submenu has three submenus (Control, Input, and Process), as shown in Figure 40.

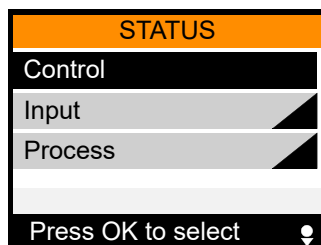

To navigate to this menu:
press the **Menu** button until the **Main Menu** appears, highlight **Status**, and press **OK**.

Figure 40: Status Menu

Control Status Submenu

The Control Status submenu has nine read-only fields, as shown in Figure 41. The gray box next to the menu shows the name and location of each field. The following table describes each field.

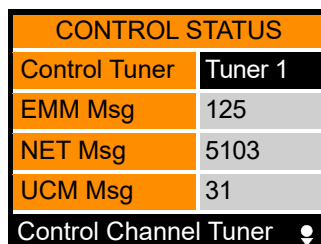

Control Channel Tuner
EMM Message Count
NET Message Count
UCM Message Count
Retune Message Count
DL Pre Message Count
DL Message Count
UA1 CAT Sequence #
UA2 CAT Sequence #

To navigate to this menu:
press **Menu** several times until the **Main Menu** appears, highlight **Status**, press **OK**, highlight **Control**, and press **OK**.

Figure 41: Control Status Submenu

Parameter	Description
Control Channel Tuner (read only)	This read-only field displays the input that is currently being used to receive IRD control messages. This field displays one of the following: Tuner 1, Tuner 2, Tuner 3, Tuner 4, ASI IN, or IP IN.
EMM Message Count (read only)	This field displays the number of Entitlement Management messages received by the unit since the last reboot.
NET Message Count (read only)	This field displays the number of Network Information messages received by the unit since the last reboot.
UCM Message Count (read only)	This field displays the number of Unit Configuration messages received by the unit since the last reboot.
Retune Message Count (read only)	This field displays the number of Retune Messages received by the unit since the last reboot.
DL Pre Message Count (read only)	This field displays the number of Code Download Preamble messages received by the unit since the last reboot.
DL Message Count (read only)	This field displays the number of Code Download messages received by the unit since the last reboot.
UA1 CAT Sequence # (read only)	The current and next Category Epoch for which Unit Address 1 is authorized.
UA2 CAT Sequence # (read only)	The current and next Category Epoch for which Unit Address 2 is authorized.

Input Status Submenu

The Input Status submenu, as shown in Figure 42, has 17 fields. To use this menu, go to the Input field, choose the desired input, and review all the fields below. The gray box next to the menu shows the name and location of each field. The following table describes each parameter.

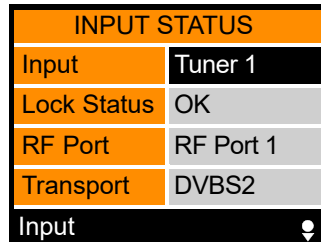

Input
Lock Status
RF Port Number
Transport Spec
Modulation Format
Frequency (MHz)
Satellite ID
Satellite Name
Polarity
Symbol Rate (Msps)
FEC Code Rate
Es/No (dB)
Eb/No (dB)
Info Rate (Mbps)
Signal Power (dBm)
Error Count
Lock Loss Count

To navigate to this menu: press **Menu** several times until the **Main Menu** appears, highlight **Status**, press **OK**, highlight **Input**, and press **OK**.

Figure 42: Input Status Submenu

Parameter	Description
Input	User-selectable input to which the following parameters apply. Choose one of the following: Tuner 1, Tuner 2, Tuner 3, Tuner 4, ASI IN, or IP IN.
Lock Status (read only)	Lock status of the selected input, as described below. Unlocked Designates the input is not locked. OK Designates the input is locked.
RF Port Number (read only)	This parameter only applies to Tuner inputs, not ASI IN or IP IN. This field displays the RF port number employed for the selected input and displays one of the following: RF Port 1, RF Port 2, RF Port 3, or Port 4.
Transport Spec (read only)	This parameter only applies to Tuner inputs, not ASI In or IP IN. This field displays the transmission standard for the acquired signal (either DVBS2, DVBS2x, 8PSK-TC, or DCII).
Modulation Format (read only)	This parameter only applies to Tuner inputs, not ASI In or IP IN. This field displays the modulation format for the acquired signal (either QPSK, 8APSK, 16APSK, 32APSK, 64APSK, 128APSK, or 256APSK).
Frequency (MHz) (read only)	This parameter only applies to Tuner inputs, not ASI In or IP IN. This value is the L-band frequency (MHz) employed for the selected input.
Satellite ID (read only)	This parameter displays the Satellite ID that is used for the selected input.
Satellite Name (read only)	This parameter only applies to Tuner inputs, not ASI In or IP IN. This parameter displays the satellite name assigned by the Programmer.

Parameter	Description
Polarity (read only)	<p>Use this parameter to view the transponder downlink signal polarity for the chosen RF Port Number (specified above). This parameter only applies to Tuner inputs, not ASI IN or IP IN. This field displays the current downlink signal polarity used for the selected input as described below:</p> <p>H/LHP Designates Horizontal or Left-hand (Circular) polarized.</p> <p>V/RHP Designates Vertical or Right-hand (Circular) polarized.</p> <p>This parameter is set by the Programmer. For specific instructions, consult your Programmer.</p>
Symbol Rate (Msps) (read only)	This parameter only applies to Tuner inputs, not ASI IN or IP IN. This value is the Modulation symbol rate (Msps) used for the selected input.
FEC Code Rate (read only)	This parameter only applies to Tuner inputs, not ASI IN or IP IN. The value displayed in this field is the Forward Error correction (FEC) coding rate used for the selected input.
Es/No (dB) (read only)	This parameter only applies to Tuner inputs, not ASI IN or IP IN. This field displays the Es/No (dB), a signal-to-noise measurement, estimated for the selected input.
Eb/No (dB) (read only)	This parameter only applies to Tuner inputs, not ASI IN or IP IN. This field displays the Eb/No (dB), a signal-to-noise measurement, estimated for the selected input.
Info Rate (Mbps) (read only)	This parameter only applies to Tuner inputs, not ASI IN or IP IN. This field displays the modulation information rate (bits) of the selected input.
Signal Power (dBm) (read only)	This parameter only applies to Tuner inputs, not ASI IN or IP IN. This field displays the Input signal level (dBm) estimated for the selected input.
Error Count (read only)	This parameter only applies to Tuner inputs, not ASI IN or IP IN. This field displays the input error count.
Lock Loss Count (read only)	This field displays the count of input signal loss events since the last reboot.

Process Status Submenu

The Process Status submenu, as shown in Figure 43, has 14 read-only fields. To use this menu, go to the Processor field, choose the desired processor, and review all the fields below. The gray box next to the menu shows the name and location of each field. The following table describes each field.

PROCESS STATUS	
PR	PR1
VCT	200
VCN	112
Service	7
Processor	

Processor
Virtual Channel Table
Virtual Channel #
Service Number
Source Name
Current Pgm Auth
Next Pgm Auth
UA number
Encryption Level
Video Lock
HD Output
SD Output
Passthru Output
Retune ID

To navigate to this menu: press **Menu** several times until the **Main Menu** appears, highlight **Status**, press **OK**, highlight **Input**, and press **OK**.

Figure 43: Process Status Submenu

Parameter	Description				
Processor	User-selectable processor to which the following parameters apply (the parameters listed below). This field displays the processor number. For example, PR3 applies to Processor 3.				
Virtual Channel Table (read only)	This field displays the Virtual Channel Table (VCT) employed by the selected processor.				
Virtual Channel # (read only)	This field displays the Virtual Channel Number (VCN) employed by the selected processor.				
Service Number (read only)	This field displays the Service (or MPEG Program) Number employed by the selected processor.				
Source Name (read only)	This field displays the name of the source associated with the specified virtual channel or service number.				
Current Pgm Auth (read only)	This field displays the current program authorization state for the selected processor.				
Next Pgm Auth (read only)	This field displays the next program authorization state for the selected processor.				
UA number (read only)	This field displays the Unit Address (UA) employed by the selected processor for service decryption.				
Encryption Level (read only)	This field displays the encryption level of the service employed by the selected processor.				
Video Lock (read only)	This field displays the video lock status for the selected processor, as described below: <table border="0" style="width: 100%;"> <tr> <td style="width: 50%;">Unlocked</td> <td style="width: 50%;">Designates the processor is unable to lock to the video.</td> </tr> <tr> <td>OK</td> <td>Designates the processor is locked to the video.</td> </tr> </table>	Unlocked	Designates the processor is unable to lock to the video.	OK	Designates the processor is locked to the video.
Unlocked	Designates the processor is unable to lock to the video.				
OK	Designates the processor is locked to the video.				

Parameter	Description
HD Output (read only)	This field displays the HD service output status for the selected processor. Enabled Designates the HD service is enabled. Disabled Designates the HD service is disabled.
SD Output (read only)	This field displays the Standard Definition (SD) service output status for the selected processor, as described below: Enabled Designates the SD service is enabled. Disabled Designates the SD service is disabled.
Passthru Output (read only)	This field displays the Pass Thru (PT) service output status for the selected processor, as described below: Enabled Designates the Pass Thru service is enabled. Disabled Designates the Pass Thru service is disabled.
Retune ID (read only)	This field displays the Retune ID assigned to the selected processor.

Diagnostics Menu

The Diagnostics menu has two submenus (Cue Tones and Alarms), as shown in Figure 44.

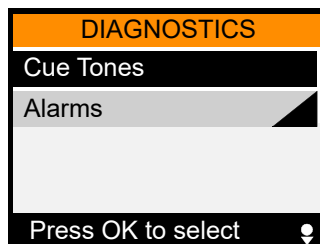

To navigate to this menu:
press the **Menu** button until the **Main Menu** appears, highlight **Diagnostics**, and press **OK**.

Figure 44: Diagnostics Menu

Cue Tones Submenu

The Cue Tones submenu has one field, as shown in Figure 45. The following table describes the parameter.

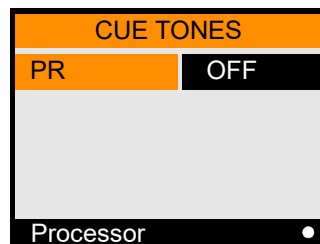

To navigate to this menu:
press **Menu** several times until the **Main Menu** appears, highlight **Diagnostics**, press **OK**, highlight **Cue Tones**, and press **OK**.

Figure 45: Cue Tones Submenus

Parameter	Description
Processor	Use this field to choose which processor will perform a cue tone test sequence. Choosing the desired processor number will send the cue tone to the associated output port. To stop the cue tone test sequence, choose OFF.

Alarms Submenu

The Alarms submenu has three submenus (Device, Service, and Alarm Test), as shown in Figure 46.

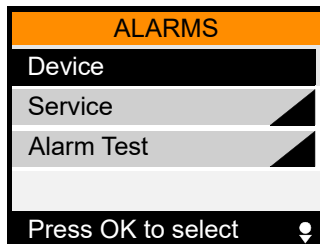

To navigate to this menu:
 press **Menu** several times until the **Main Menu** appears, highlight **Diagnostics**, press **OK**, highlight **Alarms**, and press **OK**.

Figure 46: Alarms Submenu

Device Submenu

The Device submenu has one parameter (shown in Figure 47) and is described in the table below.

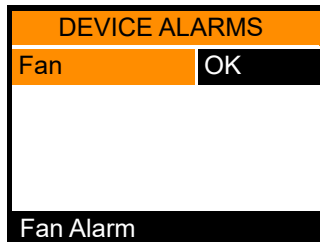

To navigate to this menu:
 press **Menu** several times until the **Main Menu** appears, highlight **Diagnostics**, press **OK**, highlight **Alarms**, press **OK**, highlight **Device**, and press **OK**.

Figure 47: Device Alarms Submenu

Parameter	Description
Fan Alarm	This read-only field displays one of the following messages:
Alarm	One or more fans have failed.
OK	All fans are operational.

Service Alarms Submenu

The Service Alarms submenu has seven fields, as shown in Figure 48. The gray box next to the menu shows the name and location of each parameter. To use this menu, go to the Processor field, choose the desired processor, and review all the fields below. The following table describes the fields.

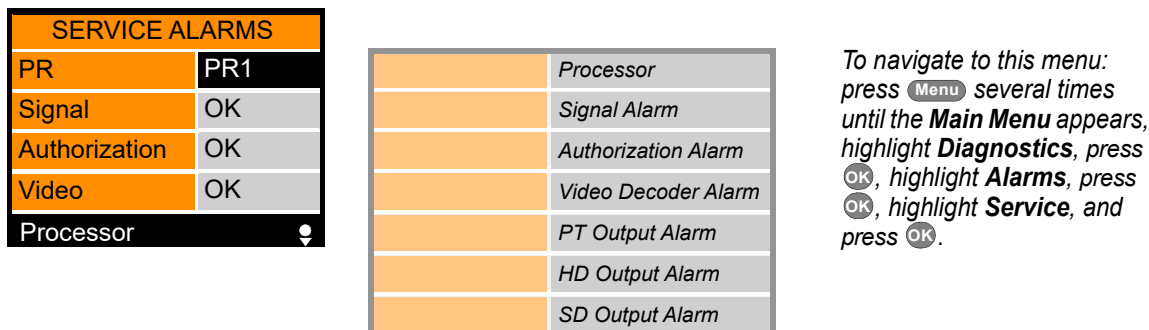
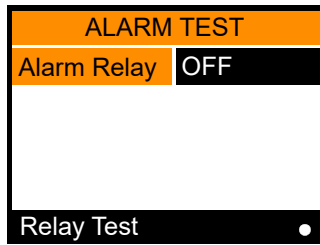

Figure 48: Service Alarms Submenu

Parameter	Description
Processor	Use this field to specify which processor's alarms to display.
Signal Alarm (read only)	This field displays one of the following messages: Alarm The specified processor does not have a signal. OK The specified processor has a signal.
Authorization Alarm (read only)	This field displays one of the following messages: Alarm The service is not authorized. OK The service is authorized.
Video Decoder Alarm (read only)	This field displays one of the following messages: Alarm Video decoding has failed. OK Video decoding is operational.
PT Output Alarm (read only)	This field displays one of the following messages: Overflow The MUX associated with this Pass Thru service is overflowing. OK The MUX associated with this Pass Thru service is operating correctly or is not in use.
HD Output Alarm (read only)	This field displays one of the following messages: Fault The transcoder failed. Overflow The mux associated with this HD processor is overflowing. OK The mux associated with this HD processor is operating correctly or is not in use.
SD Output Alarm (read only)	This field displays one of the following messages: Fault The transcoder failed. Overflow The mux associated with this SD processor is overflowing. OK The mux associated with this SD processor is operating correctly or is not in use.

Alarm Test Submenu

The Alarm Test submenu has one parameter (shown in Figure 49) and is described in the table below



To navigate to this menu:
 press **Menu** several times
 until the **Main Menu** appears,
 highlight **Diagnostics**, press
OK, highlight **Alarms**, press
OK, highlight **Alarm Test**,
 and press **OK**.

Figure 49: Alarm Test Submenu

Parameter	Description
Relay Test	Use this field to initiate an Alarm Relay test. To initiate this Alarm Relay test, set this field to ON. While running the test, do not exit the field. To stop the Alarm Relay test, set this field to OFF or exit the field. Exiting the field will automatically change the field to OFF and stop the Alarm Relay test.

Using the Web GUI to Configure IP Parameters

Overview

This chapter describes how to use a web browser on a personal computer (PC) to view the unit's configuration, download the Operator Guide PDF file, and change the IP network address settings.

To access the unit's GUI

1. Verify that the personal computer is on the same IP subnet as the IRD's Control port so that the unit is accessible remotely.
2. To access the unit from a PC, open an Internet Browser window and type the IP address of the Control port. ARRIS recommends using Chrome or Firefox.

For example, type **192.168.0.100** and press ENTER.
Do not type www or http.

3. When the Login window appears (shown in Figure 50), leave the Password field blank and select the Login button.

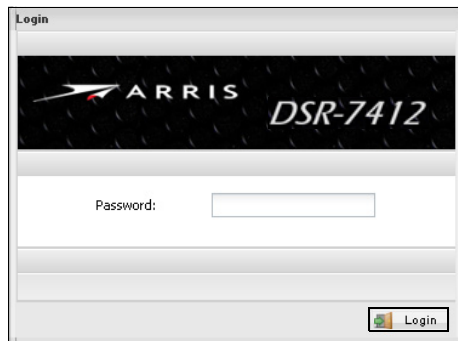

Figure 50: Login Screen

Optional

- If the Operator Guide PDF is not yet downloaded to the computer's hard drive, select the Help button and download the Operator Guide PDF to the computer's hard drive. To do this, right-click on the **pdf download** link, and select **Save link as...** When the Directory window appears, navigate to the desired location on your computer's hard drive (usually the desktop) and select Open.

Note: When it is time to close the unit's browser window, select the Close button (**X**) in the upper-right corner.

Reviewing/Changing IP Address Settings

To view the System Network screen, go to the System pulldown menu and choose Network. Before editing IP addresses, study the descriptions in Figure 51 (below).

The unit's firmware version is located here.

To see the Web GUI version OS, use the mouse to point to the firmware version number.

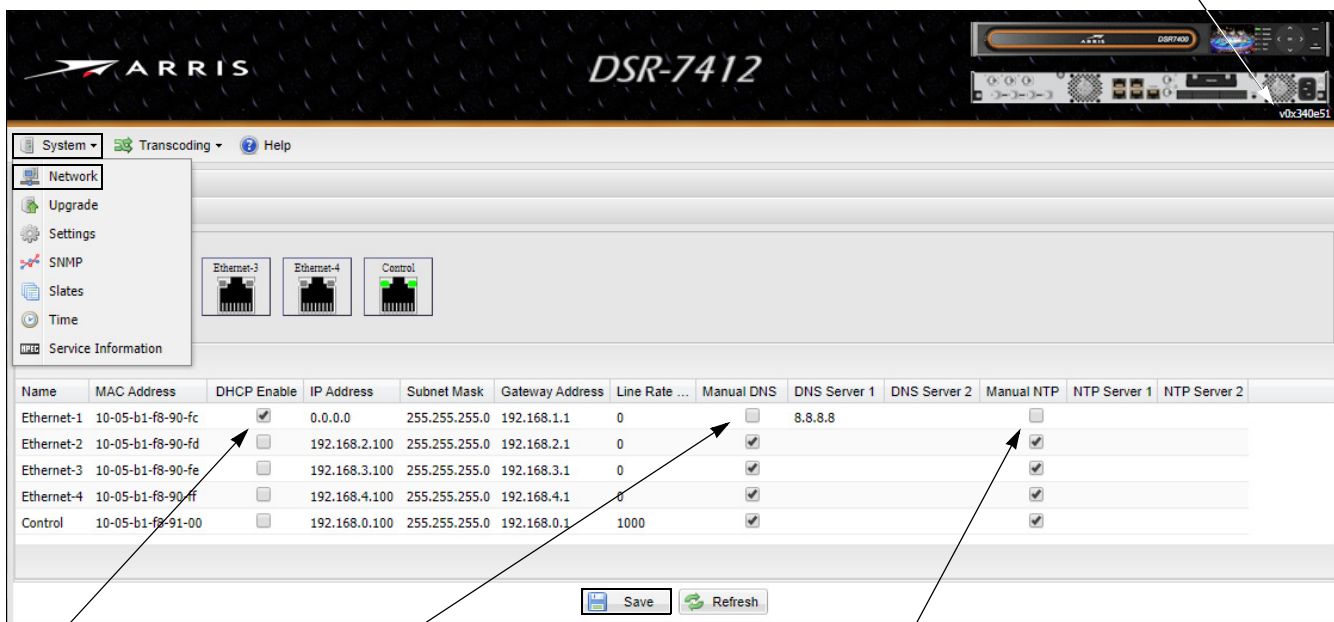

If the DHCP Enable checkbox is checked, the three fields to the right (IP Address, Subnet Mask, and Gateway Address) cannot be edited manually because the addresses are being supplied by the DHCP server.

If the DHCP Enable checkbox is not checked, the three fields to the right can be edited manually.

If the Manual DNS checkbox is not checked, the two fields to the right (DNS Server 1 and DNS Server 2) cannot be edited manually because the addresses are being supplied by the DHCP server.

A blue IP address means the DNS server is used by the system. A black IP address means the DNS server is not used by the system.

If the Manual DNS checkbox is checked, the two DNS Server IP addresses can be edited manually.

If the DHCP Enable checkbox (described on the left) is not checked, the Manual DNS checkbox is then always checked because there is no DHCP server providing DNS Server IP addresses.

If the Manual NTP checkbox is not checked, the two fields to the right (NTP Server 1 and NTP Server 2) cannot be edited manually because the addresses are being supplied by the DHCP server.

A green IP address designates that the system time is synchronized with that NTP server. The system can synchronize to only one NTP server at a time, therefore only one green NTP Server IP address is shown in the GUI.

A blue IP address designates that NTP server is also used by the system as reference.

A black IP address means the NTP server is not used by the system.

If the Manual NTP checkbox is checked, the two NTP Server IP addresses can be entered manually.

If the DHCP Enable checkbox (described on the left) is not checked, the Manual NTP checkbox is then always checked because there is no DHCP server providing NTP Server IP addresses.

Figure 51: System Network Screen

Optional

To manually change the unit's IP address settings

Note: IP Address settings are typically specified during the installation process.

1. Go to the System pulldown menu and choose **Network**, as shown in Figure 51 on page 64.
2. If it is necessary to edit these settings, make sure the checkboxes are configured as described in Figure 51 on page 64.
3. Double-click on the field and edit the IP address as needed.

IMPORTANT: Changing the Control port configuration may result in loss of the Web GUI connection.

4. When all changes are complete, select the Save button at the bottom of the window.
5. When the following message appears, select Yes.

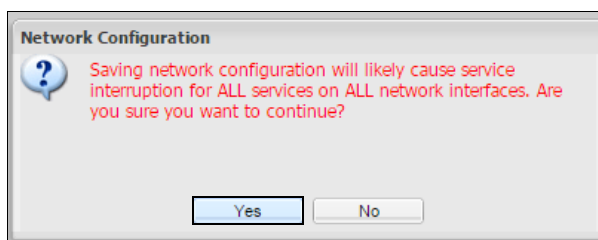

Tip: If it is necessary to return to the Configuration Diagram, go to the Configuration pulldown menu and choose **IO View**, as shown on page 67.

DHCP Supported Parameters and Auto-Fill Capabilities

DHCP auto-fill capabilities may be used for both video distribution schemes:

- Satellite Video Distribution
- CDN Video Delivery

By default, the IRD employs the Dynamic Host Control Protocol (DHCP) for automatic configuration of the Ethernet 1 port. The affiliate's public network access device (e.g., gateway) or Internet Service Provider (ISP) network should provide a DHCP server(s) for configuring (leasing) address assignments to the IRD. Table 7 lists the DHCP parameters that are supported by the DSR-7400s.

Table 7: DHCP Parameters Supported By The DSR-7400s

Parameter	Description	Mandatory
IP Address	IP Version 4 Address	Yes
Subnet Mask	IP Version 4 Mask	Yes
Gateway	Default Gateway	Yes
DNS Server	Domain Name Server - Up to two are supported.	Yes
NTP Server	Network Time Protocol Server - Up to two are supported.	No

DHCP Implementation

When implementing DHCP, ARRIS recommends using a customer-provided DHCP server to auto-fill the following fields:

- IP Address For Ethernet Port 1 (the input port)
For a typical configuration (addressing only the unit’s input port), the Subnet Mask and Gateway IP Address must be added.
- DNS Server IP Address(es)
At least one DNS Server IP address is required.
- NTP Server IP Address(es)
At least one NTP Server IP address is required.

Once the DHCP server is configured to provide these IP addresses information, the unit can be powered up to auto-acquire each of the necessary settings for Ethernet port 1. Figure 52 shows an example of how the unit uses the default settings for Ethernet port 1 to auto-fill the necessary fields in the Network submenu.

These settings can be performed using the IRD’s front-panel menu system (shown below) or from the Web GUI.

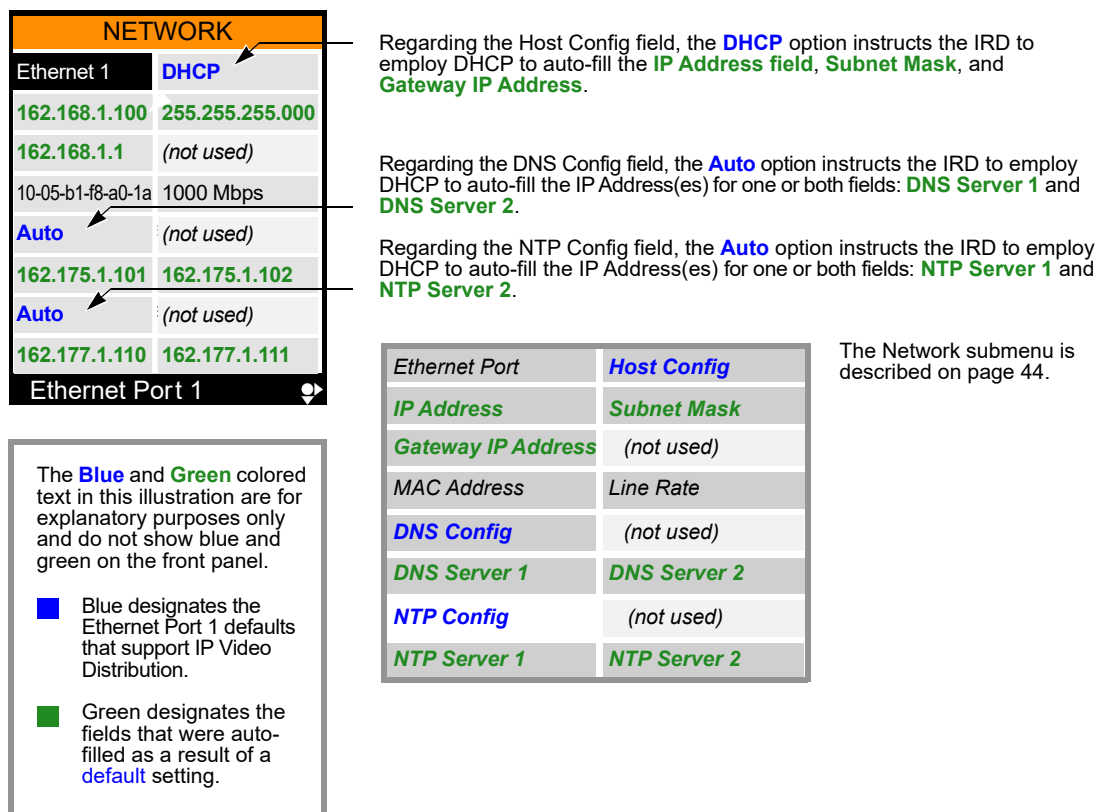

Figure 52: Network Submenu - Ethernet Port 1 Defaults That Assist With CDN Video Delivery

At this point, the operator can rest assured that the basic IP addresses are configured properly. Now the operator can go to the Quick Install menu (described on pages 41 and 42), change the Input port to IP, and choose the desired Programmer ID.

Viewing the Configuration Diagram

Overview

Use the Transcoding Diagram to review how the Transcoding Configuration routes the various signals within the unit.

Note: The unit's transcoding configuration is defined at the uplink and cannot be altered using the Web GUI.

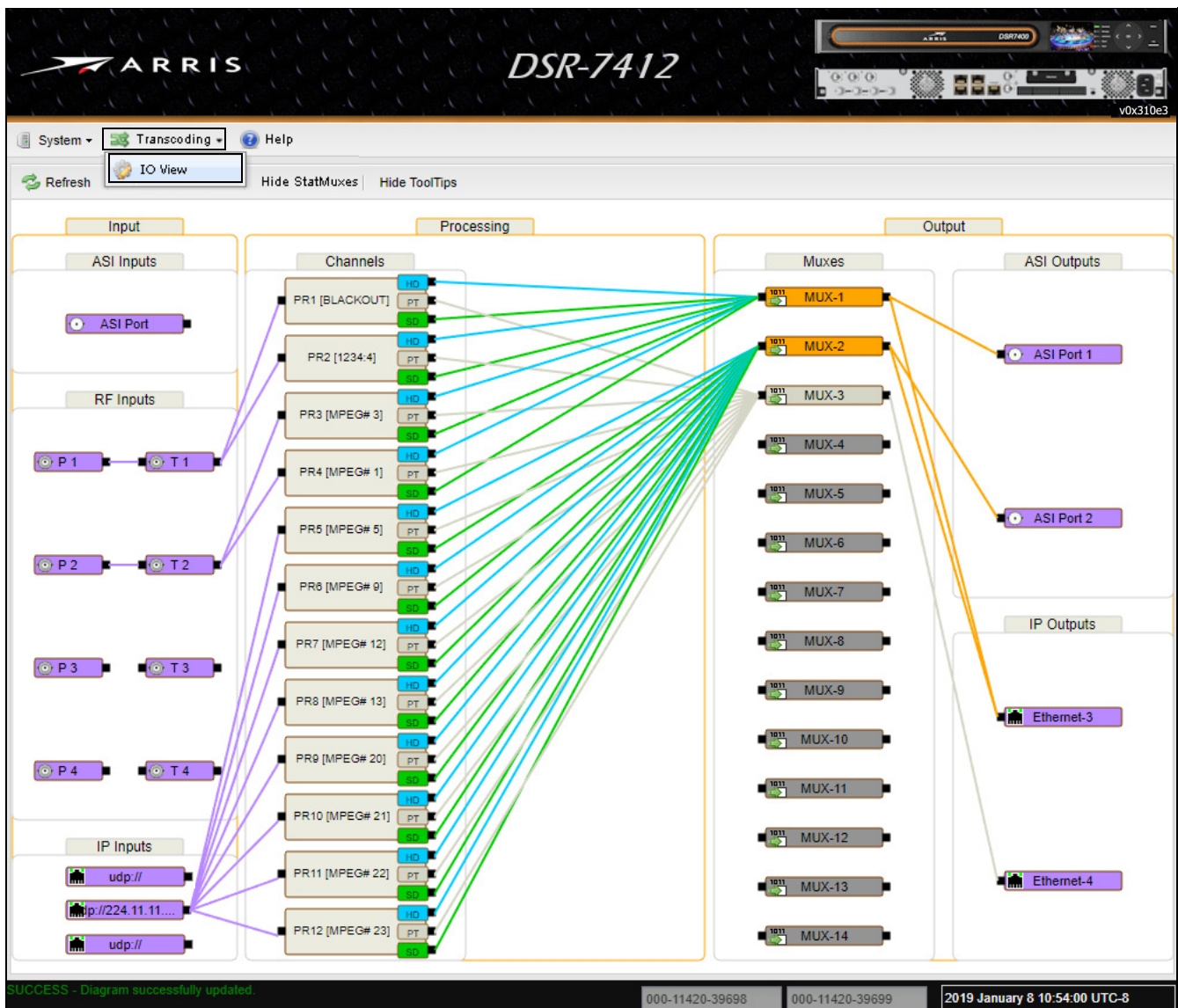

Figure 53: Transcoding Diagram - IO View (Example)

To view the Transcoding Diagram

1. Use a personal computer to login to the decoder. For details, see "To access the unit's GUI" on page 63.
2. Go to the Transcoding pulldown menu and choose IO View, as shown in Figure 54.
3. Use the following pages in this chapter to review the basic layout, color designations, and how to evaluate the unit's current transcoding configuration.

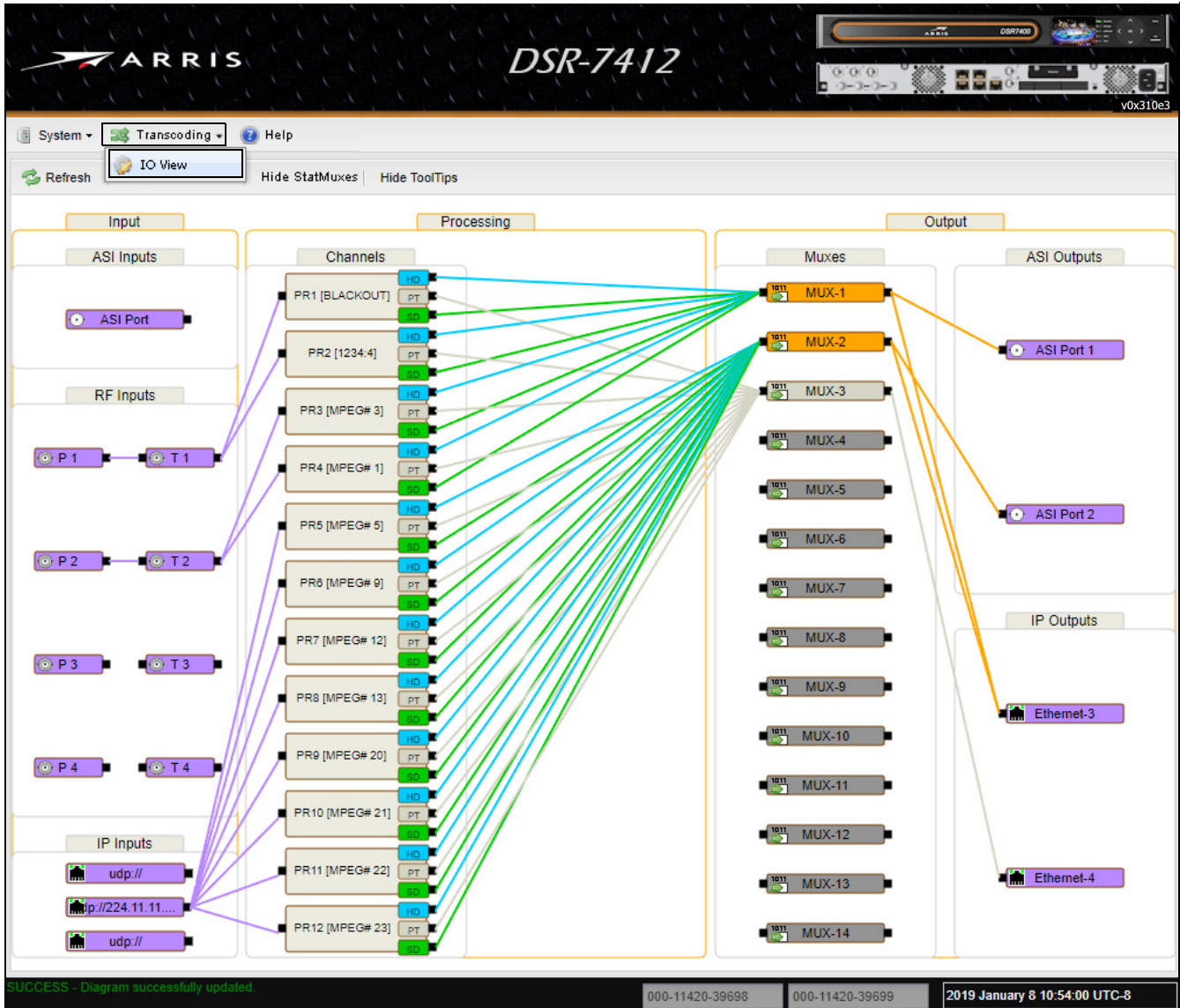
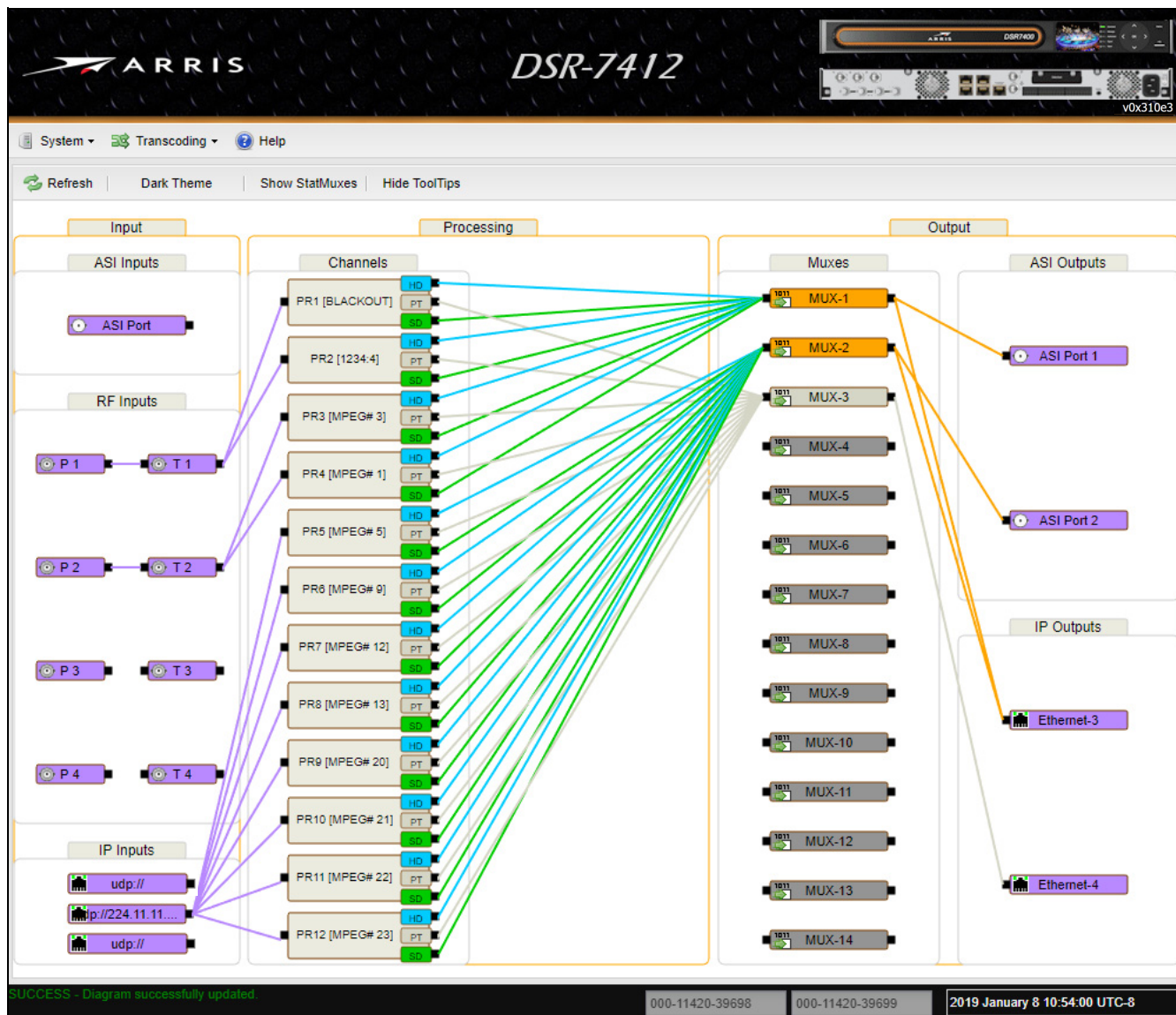

Figure 54: Transcoding Diagram - Basic Layout (Example)

Basic Layout

The DSR-7400 Series Transcoder/Receiver has a Transcoder screen that uses an icon-driven diagram that shows how the signals are routed through the unit, from the Input ports (left-most column) to the Output ports (right-most column). Figure 55 shows the transcoding diagram with an example configuration.



Inputs Column

The unit provides one ASI input port, four RF inputs (P1, P2, P3, and P4), and the IP Inputs section.

Tuners

The unit provides four tuners (T1, T2, T3, and T4).

Channels Column

Each model has a set number of transcoders:

7403 : 3 transcoders
7406 : 6 transcoders
7412 : 12 transcoders

Each transcoder has three signals: (High Definition {blue}, Standard Definition {green}, and Pass Thru {gray}).

StatMuxes Column

Each model has a set number of statmuxes:

7403 : 2 statmuxes
7406 : 4 statmuxes
7412 : 6 statmuxes

The StatMuxes column can be hidden by selecting the Hide StatMuxes button at the top of the screen.

Muxes Column

Each model has a set number of muxes:

7403 : 5 muxes
7406 : 8 muxes
7412 : 14 muxes

Each mux can be routed to one or more output ports.

Output Ports Column

Each model provides four output ports to distribute the video services:

The two ASI output ports can receive only one mux signal, each.

The two Ethernet output ports (Ethernet 3 and Ethernet 4) can receive multiple mux signals.

Figure 55: Transcoding Diagram - Functionality (Example)

Lines and Color Designations

Signal flows are designated by colored lines. Figure 56 shows how the Transcoding Diagram uses colored lines and icons to designate routing within the unit.

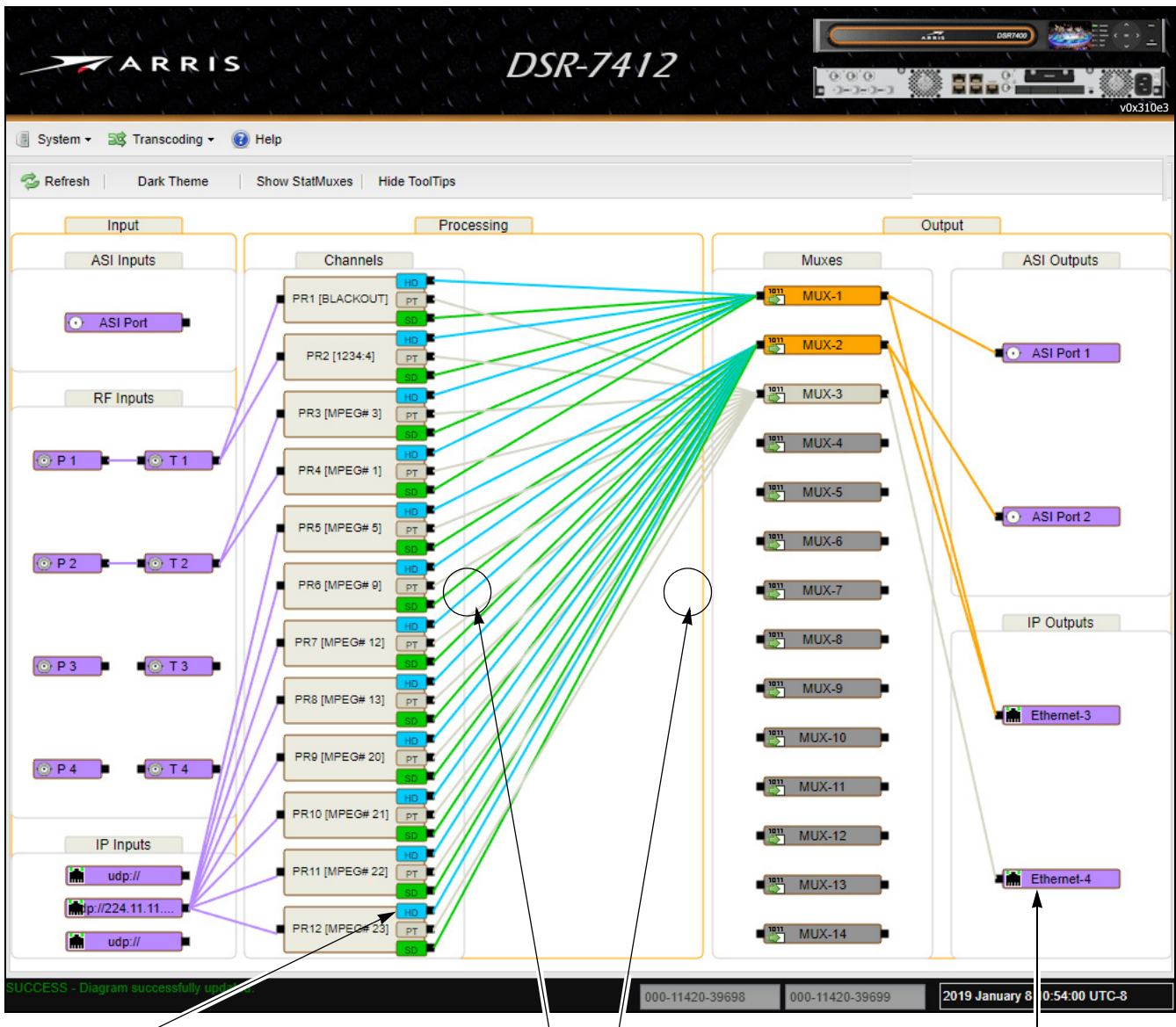

Color designations for the Channels Column are described in "Transcoding Diagram - Functionality (Example)" on page 69.

When horizontal lines seem to disappear, select the Hide StatMuxes button or Show StatMuxes button. This will show the rest of the configuration.

Output ports are always Magenta.

Figure 57 on page 71 shows the result of selecting the Hide StatMuxes button.

Link	Color	Description
	Gray	Pass Thru Link
	Green	SD Link
	Red	Link that is currently disabled
	Magenta	Highlighted Link
	Gold	Two or more services (HD, PT, SD)

Mux	Color	Description
	Blue	Mux receiving only HD services
	Light Gray	Mux receiving only Pass Thru services
	Green	Mux receiving only SD services
	Gold	Mux receiving two or more services (HD, PT, SD)
	Dark Gray	Mux is undefined

Figure 56: Transcoding Diagram - Color Designations (Example)

Transcoding Buttons

Figure 57 describes the four buttons at the top of the Transcoding screen and how to show (and hide) the StatMuxes column.

Refresh

Use this button to refresh the screen and show the most-recently saved configuration.

Dark Theme

Use this button to toggle between a black and white background.

Show/Hide StatMuxes

Use this button to show or hide the StatMuxes column (see description below).

Show/Hide ToolTips

Use this button to show or hide the ToolTips.

When ToolTips are on, use the mouse to roll over an icon in the diagram. This will display a light blue information box with the related setting, as shown in Figures 58 through 63 on the following pages.

ToolTips are described in Tables 8 through 13 on the following pages.

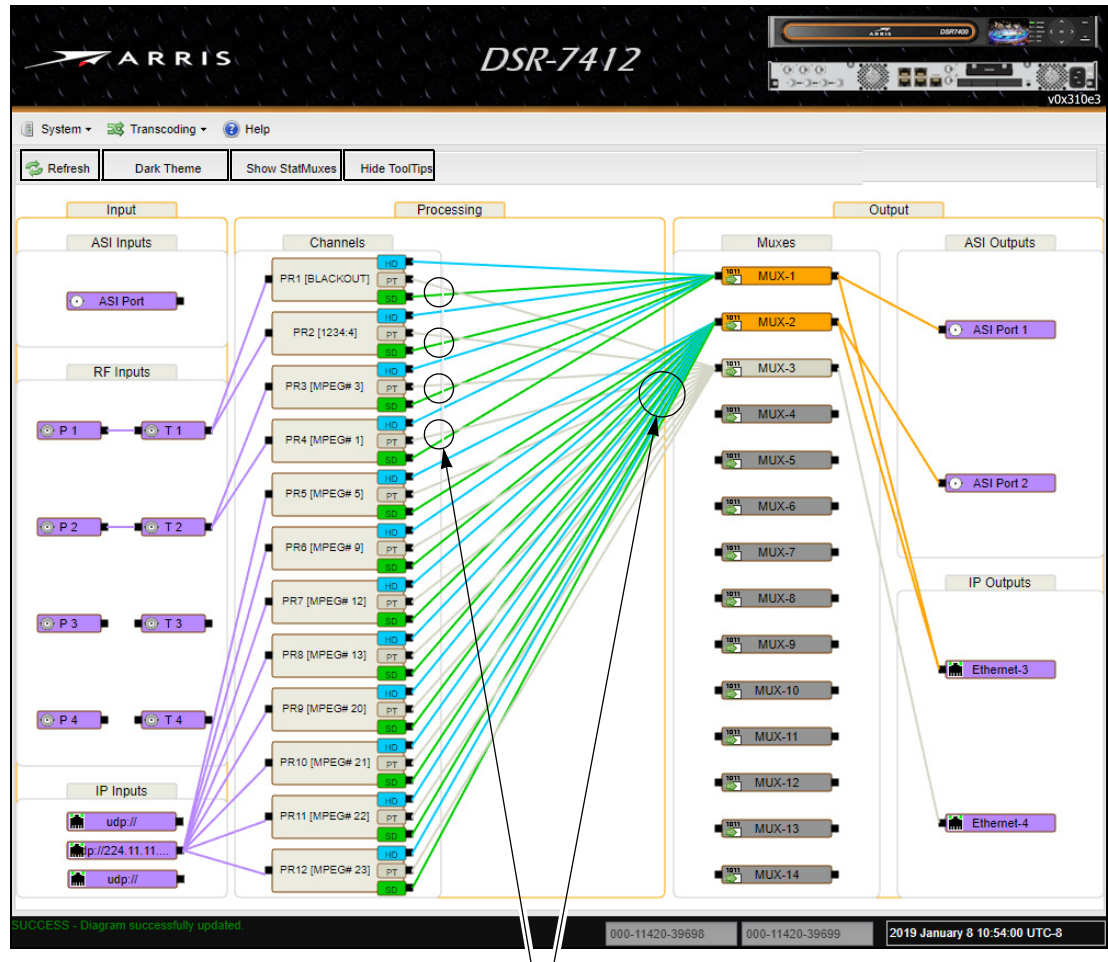

When horizontal lines seem to disappear, select the Hide StatMuxes button or Show StatMuxes button. This will show the rest of the configuration.

Figure 56 on page 70 shows the result of selecting the Show StatMuxes button.

Figure 57: Transcoding Diagram - Hidden StatMux Column (Example)

ToolTips

ToolTips are blue description boxes that provide status information for a given item. To display a ToolTip, use the mouse to rollover one of the items in the Transcoding Diagram. For example, rolling over the ASI Input icon in the Input column causes the Input ASI ToolTip to appear (shown in Figure 58).

Note: If the ToolTip does not appear, select the Show ToolTips button at the top of the Transcoding Diagram. If it is necessary to turn off ToolTips, select the Hide ToolTips button.

Input Section - ASI Inputs, RF Inputs, and Tuners

Figure 58 shows the two ToolTips that are available in the Input Column (far-left column). Table 8 describes the fields in each ToolTip.

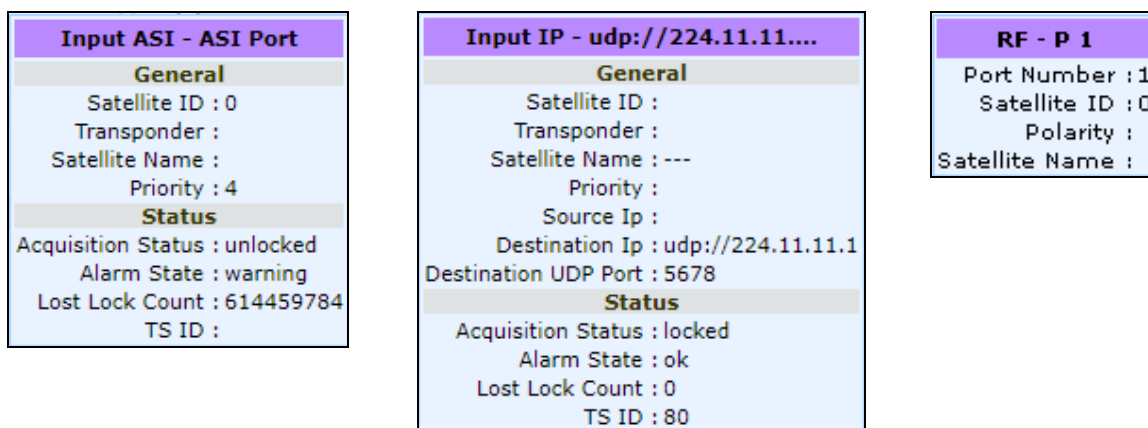

Figure 58: Transcoding Diagram ToolTips - Input Column (Input ASI, IP, and RF Ports)

Table 8: Transcoding Diagram ToolTips - Input Column (Input ASI, IP, and RF Ports)

Parameter	Description
Input ASI - ASI Port – General	
Satellite ID	The ID of the satellite that is connected to the ASI port, if any. The Satellite ID is specified within the transport stream.
Transponder	The ID of the transponder that is connected to the ASI port, if any. The Transponder ID (1 to 24) is specified within the transport stream.
Satellite Name	The satellite name of the specified Satellite ID (described above).
Priority	The priority of the input if multiple inputs are used to receive the same satellite and transponder. Zero (0) takes highest priority.
Input ASI - ASI Port – Status	
Acquisition Status	The acquisition state (locked or unlocked) of the input.
Alarm State	The alarm state of the input.
Lost Lock Count	Count of input signal acquisition loss events since the last reboot.
TS ID	The transport stream ID of the input signal.
Input IP - IP Port – General	
Satellite ID	The ID of the satellite that is connected to the IP port, if any. The Satellite ID is specified within the transport stream.
Transponder	The ID of the transponder that is connected to the IP port, if any. The Transponder ID (1 to 24) is specified within the transport stream.
Satellite Name	The satellite name of the specified Satellite ID (described above).

Table 8: Transcoding Diagram ToolTips - Input Column (Input ASI, IP, and RF Ports)

Parameter	Description
Priority	The priority of the input if multiple inputs are used to receive the same satellite and transponder. Zero (0) takes highest priority.
Source Ip	The IP address of the source that is providing the input transport stream. Use this field if it is intended for use on an IGMPv3-compliant network.
Destination Ip	The destination IP address of the transport stream to be processed.
Destination UDP Port	The destination UDP port associated with the input transport stream.
Input IP - IP Port – Status	
Acquisition Status	The acquisition state (locked or unlocked) of the input.
Alarm State	The alarm state of the input.
Lost Lock Count	Count of input signal acquisition loss events since the last reboot.
TS ID	The transport stream ID of the input signal.
RF Inputs (P1, P2, P3, and P4)	
Port Number	This number corresponds to one of the four RF input ports on the back panel.
Satellite ID	The ID of the satellite that is connected to the input.
Polarity	The polarity of the satellite transmission, either H/LHP or V/RHP.
Satellite Name	The name of the satellite associated with specified Port Number (defined above).

The Tuner fields are shown in Figure 59 and described in Table 9 on page 74.

Tuner - T 1
General
Port Number : 1
Transponder : 1
Frequency : 1430
Symbol Rate : 30
Code Rate :
Modulation : DVBS2
Status
Acquisition Status : unlocked
Alarm State : critical
TS ID :
Bit Error Rate : 0
Code Error : 0
Config State : assigned
Eb/No : 0
Es/No : 0
Code Rate : 1/2
Frequency Offset : 3000000
Lost Lock Count : 0
Mod Method : QPSK
RF Level : -81.653
Symbol Rate : 30

Figure 59: Transcoding Diagram ToolTips - Input Column (Tuners)

Table 9: Transcoding Diagram ToolTips - Input Column (Tuners)

Parameter	Description
Tuners (T1, T2, T3, and T4) – General	
Port Number	This number corresponds to one of the four RF input ports on the back panel.
Transponder	The input signal's transponder value (1 to 24).
Frequency	The input signal's input signal frequency for the specified Input Port Number described above.
Symbol Rate	The input signal's symbol rate, designated in Msps.
Code Rate	The input signal's code rate.
Modulation	The input signal's Modulation Mode (either DVBS2, DCII, DVBS2x, or 8PSK-TC).
Tuners (T1, T2, T3, and T4) – Status	
Acquisition Status	The acquisition state (locked or unlocked) of the input.
Alarm State	The alarm state of the input.
TS ID	TS ID – The Transport Stream ID of the input signal.
Bit Error Rate	Bit error rate of the input signal.
Code Error	Count of detected code errors.
Config State	Configuration state of the tuner.
Eb No	Ratio of signal energy per bit (Eb) to noise density (No).
Es No	Ratio of signal energy per symbol (Es) to noise density (No).
Code Rate	Forward error correction (FEC) code rate of the input signal.
Frequency Offset	Difference between actual and configured input signal carrier frequency.
Lost Lock Count	Count of input signal acquisition loss events.
Mod Method	Modulation scheme used by the input signal (DVBS2, DCII, DVBS2x, or 8PSK-TC).
RF Level	Input signal level, in dBm.
Symbol Rate	Input signal symbol rate (in Msps).

Processing Section - Channels and StatMuxes

Figure 60 shows the ToolTips available in the Channels Column and the StatMuxes Column. Table 10 describes the fields in each ToolTip.

Processing Block

Input Channel

VCT : 1234

VCN : 4

Satellite : 100

Transponder : 1

Polarity : V/RHP

OutputProcessor - PT

General

Xcdr# : 1

Enabled : true

SMG - SMUX-1

Group Bit Rate : 35 Mbps

Resolution Type : UNDEFINED

Figure 60: Transcoding Diagram ToolTips - Processing Section - Channels Column

Table 10: Processing Section ToolTips - Channels Column and StatMuxes Column

Parameter	Description
Processing Block – Input Channel	
VCT	The Virtual Channel Table (VCT) associated with this input signal.
VCN	The Virtual Channel Number (VCN) associated with this input signal.
Satellite	The ID of the satellite associated with this input signal.
Transponder	The transponder number associated with this input signal.
Polarity	The polarity (H/LHP or V/RHP) associated with this input signal.
Output Processor - PT – General	
Xcdr#	The processor number (1 to 12) that is associated with this video signal.
Enabled	The processor's current activity state (either true or false).
SMG (Statmux Group)	
Group Bit Rate	The bit rate, in Mbps, of the statistical multiplex group.
Resolution Type	The transcoder resolution type assigned to the statistical multiplex group (either HD, SD, or UNDEFINED).

The Output Processor for PT (Pass Thru) fields and HD fields are shown in Figure 61 and described in Table 11 (page 76).

The Output Processor for SD fields are shown in Figure 62 (page 77) and described in Table 12 (page 77).

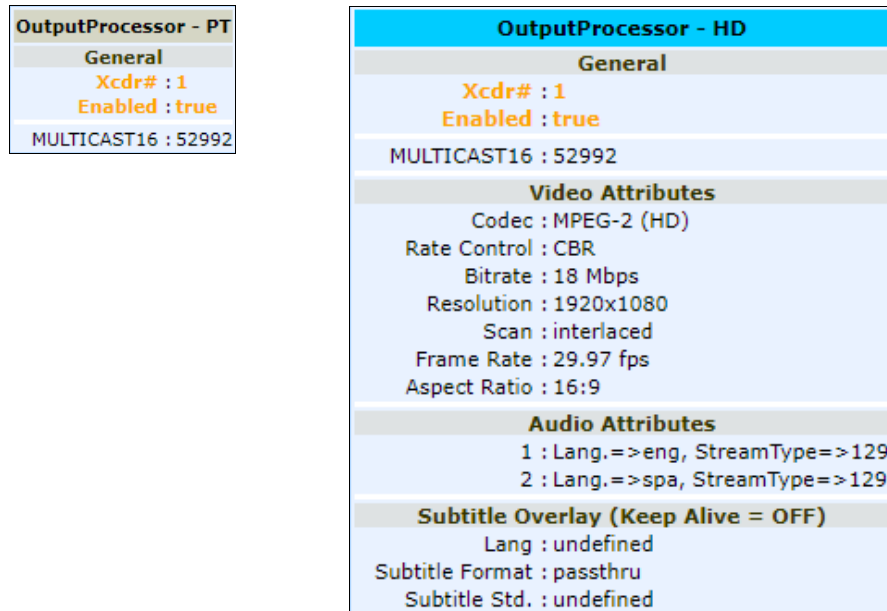

Figure 61: Transcoding Diagram ToolTips - Output Processor HD

Table 11: Output Processor - Output Processor PT and HD

Parameter	Description
Output Processor PT	
Xcdr#	The processor number (1 to 12) that is associated with this video signal.
Enabled	The processor's current activity state (either true or false).
MULTICAST16	This field displays the multicast address associated with the DEM group that is currently-assigned to this group. This field only appears if multicast is defined by the Programmer.
Output Processor – HD – General	
Xcdr#	The processor number (1 to 12) that is associated with this video signal.
Enabled	The processor's current activity state (either true or false).
MULTICAST16	This field displays the multicast address associated with the DEM group that is currently-assigned to this group. This field only appears if multicast is defined by the Programmer.
Output Processor – HD – Video Attributes	
Codec	Displays the Output video signal's compression format (either MPEG-2 or MPEG-4).
Rate Control	Displays either CBR (Constant Bit Rate) or VBR (Variable Bit Rate {Statmux}).
Min Bitrate	Displays the video signal's minimum bit rate. This field only appears if the Rate Control parameter is set to VBR.
Max Bitrate	Displays the video signal's maximum bit rate. This field only appears if the Rate Control parameter is set to VBR.
Bitrate	Displays the video signal's bit rate. This field only appears if the Rate Control parameter is set to CBR.
Resolution	Displays HD Output resolution (either 1920x1080 or 1280x720).
Scan	Displays the Output video's scanning method (either interlaced or progressive).
Frame Rate	This field specifies the Output video's frame rate. For ATSC it will display either 29.97 or 59.94. PAL is currently not supported.
Aspect Ratio	This field specifies the Output video's aspect ratio (either 4:3 or 16:9).
Output Processor – HD – Audio Attributes	
Lang.	This field displays the language associated with the audio stream.
StreamType	This field displays the audio type that is as defined in the PMT for the audio stream.
Output Processor – HD – Subtitle	
Lang.	This field displays the language associated with subtitle stream.
Subtitle Format	This field indicates whether the subtitles are passed thru or rendered. The field displays either passthru or overlay [rendered within the unit].
Subtitle Std	Indicates which subtitle standard is present. The field displays either DVB, DCII, or undefined.

Output Processor - SD	
General	
Xcdr# :	1
Enabled :	true
MULTICAST16 :	52992
Video Attributes	
Codec :	MPEG-2 (SD)
Rate Control :	CBR
Bitrate :	6 Mbps
Resolution :	704x480
Scan :	interlaced
Frame Rate :	29.97 fps
Aspect Ratio :	4:3
SD Convert Method :	AFD
SD Default Aspect Ratio :	LetterBox
AFD Output :	false
Audio Attributes	
1 :	Lang.=>eng, StreamType=>129
2 :	Lang.=>spa, StreamType=>129
Subtitle Overlay (Keep Alive = OFF)	
Lang :	undefined
Subtitle Format :	passthru
Subtitle Std. :	undefined

Figure 62: Transcoding Diagram ToolTips - SD

Table 12: Output Processor SD

Parameter	Description
Output Processor – General	
Xcdr#	The processor number that is associated with this video signal.
Enabled	The processor’s current activity state (either true or false).
MULTICAST 16	This field displays the multicast address associated with the DEM group that is currently-assigned to this group. This field only appears if multicast is defined by the Programmer.
Output Processor – Video Attributes	
Codec	This field displays the output video signal’s compression format (either MPEG-2 or MPEG-4).
Rate Control	Displays either CBR (Constant Bit Rate) or VBR (Variable Bit Rate {Statmux}).
Min Bitrate	Displays the video signal’s minimum bit rate. This field only appears if the Rate Control parameter is set to VBR.
Max Bitrate	Displays the video signal’s maximum bit rate. This field only appears if the Rate Control parameter is set to VBR.
Bitrate	Displays the video signal’s bit rate. This field only appears if the Rate Control parameter is set to CBR.
Resolution	This field displays the SD output video resolution (either 528x480, 544x480, 704x480, or 720x480).
Scan	This field displays the output video’s scanning method (either interlaced or progressive).
Frame Rate	This field specifies the output video’s frame rate. For ATSC it will display either 29.97 or 59.94. PAL is currently not supported.
Aspect Ratio	This field specifies the output video’s aspect ratio (either 4:3 or 16:9).
SD Convert Method	This field specifies how the ARC method is determined (either SD Default Aspect Ratio, AFD (default), or AFD without Timeout).

Table 12: Output Processor SD (Continued)

Parameter	Description
SD Default Aspect Ratio	This field specifies the unit's default aspect ratio for SD video (either Letterbox, Center Cut, 14:9, or 16:9).
AFD Output	This field specifies if the video stream outputs AFD in the video stream (either true or false). The true option is currently unsupported.
Audio Attributes	
Lang.	This field displays the language associated with the audio stream.
StreamType	This field displays the audio type that is as defined in the PMT for the audio stream.
Subtitle	
Lang.	This field displays the language associated with subtitle stream.
Subtitle Format	This field indicates whether the subtitles are passed thru or rendered. The field displays either passthru or overlay [rendered within the unit].
Subtitle Std	This field indicates which subtitle standard is present. The field displays either DVB, DCII or undefined.

Output Section - Muxes, ASI Outputs, and IP Outputs

Figure 63 shows the three ToolTips that are available in the Muxes column and Output column (the two far-right columns). Table 13 describes the fields in each ToolTip.

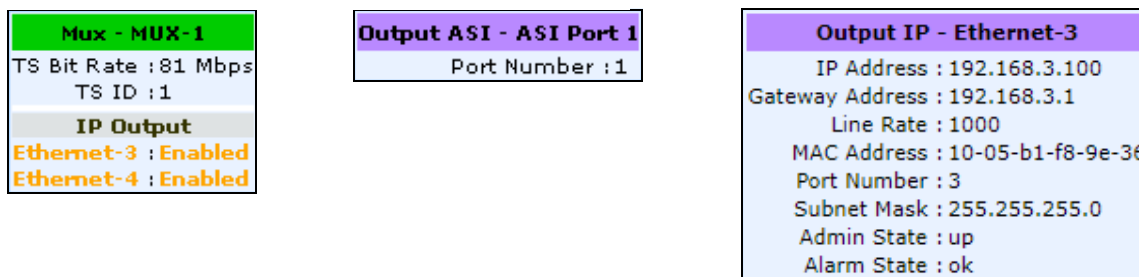

Figure 63: Transcoding Diagram ToolTips - Output Section - Muxes Column

Table 13: Transcoding Diagrams ToolTips - Muxes Section and Output Section

Parameter	Description
Muxes Column	
TS Bit Rate	The transport stream bit rate of the output multiplex in Mbps.
TS ID	The transport stream identification assigned to the output multiplex.
IP Output	
Ethernet-3 and Ethernet-4	Indicates the configured state of the Gigabit Ethernet port on the back panel (either Enabled or Disabled).
Output ASI	
Port Number	This number corresponds to one of the two ASI output ports on the back panel.
Output IP	
IP Address	The IP address assigned to this IP Output port (located on the back panel).
Gateway Address	The IP address of the gateway connected to this Gigabit Ethernet port.
Line Rate	The port's transfer bit rate in Mbps.
MAC Address	The MAC address that corresponds to this Gigabit Ethernet port.
Port Number	The port number associated with this Gigabit Ethernet port on the back panel.
Subnet Mask	The subnet mask assigned to this Gigabit Ethernet port.
Admin State	The port's current admin state.
Alarm State	The port's current alarm state.

Viewing NTP Servers

Use the System NTP Servers screen to view which NTP server is synchronized. To view this screen, select System and choose Time. The following table describes each field.



Parameter	Description	
IP Address	This field displays one or two NTP IP addresses. These two IP addresses can be edited from the front panel, as described on page 44, and from the Web GUI, described on the System > Network screen (located on page 64).	
Synchronized	Checked checkbox	Designates that system time is synchronized to the NTP server.
	Unchecked checkbox	Designates that system time is not synchronized to the NTP server.
Stratum	This field displays the NTP server stratum value. Lower values provide a better clock source.	
Jitter (usec)	This field display the NTP jitter and is a measurement of the variance in latency on the network.	

Configuring UDP/IP Input and Output

Overview

This chapter describes how to use the Web GUI's Transcoding Diagram to configure IP input (below) and IP output (page 84). The unit's back panel has two IP input ports (Ethernet 1 and 2) and can process IP input from one port at a time. This unit has two IP output ports (Ethernet 3 and 4) and can simultaneously process and output both ports.

Procedure

To configure UDP/IP Input

This procedure must be performed at the downlink.

1. Verify that an Ethernet cable is connected to the desired port on the back panel (either Ethernet-1 or Ethernet-2).
2. Log in to the Web GUI (described on page 63), go to the Transcoding Diagram, select Transcoding and choose IO View.
3. Go to the Input column, right-click on a virtual IP port, and choose Configure IP Input.
4. When IP Input Configuration dialog box appears (shown in Figure 64), use Table 14 on page 82 to specify the desired settings, and select the Apply button.

The Programmer cannot override these parameters.

Use the mouse to enter a checkmark.

If a Channel Select method will be used for this configuration (VCT/VCN), set these two fields as directed by the Programmer.

If an MPEG Select method will be used for this configuration, leave these two fields blank.

Choose either Ethernet-1 or Ethernet-2.

Note: This field is necessary when defining an IGMPv3-compliant network.

The HLS configuration is defined by the Programmer. For more details, see "Viewing The Programmer's Service Information" on page 91.

Figure 64: Editing Fields Within the IP Input Configuration Dialog Box (Example)

Table 14: IP Input Configuration Parameters

Parameter	Description
Main Section	
Satellite ID	Specify the ID of the satellite that is associated with the IP input transport stream (either Ethernet 1 or Ethernet 2). Contact the Programmer for this value. For more details, see Figure 64 on page 81.
Transponder	Specify the transponder associated with the IP input transport stream. Contact the Programmer for this value. For more details, see Figure 64 on page 81.
IP Config Section	
Network Interface	Use this field to choose the desired Ethernet port to use as the source (either Ethernet 1 or Ethernet 2).
Source IP Address	Use this field to enter the IP address of the source that is providing the input transport stream. Use this field if it is intended for use on an IGMPv3-compliant network.
Destination IP Address	Use this field to enter the destination IP address of desired input transport stream.
Destination UDP Port	Use this field to enter the destination UDP port that is associated with the input transport stream. Enter a value from 1 to 65535.

IMPORTANT: The following two steps describe how to specify the desired program from the transport stream. Work closely with the Programmer to ensure the proper values are entered in the Input Configuration dialog box.

- Go to the Processor column, locate the processor to use for IP input, right-click on the processor, and choose Configure Input.
- When the Input Configuration dialog box appears, use the mouse to specify the desired input method (either Channel Select or MPEG Select), and set the two fields as needed. Figure 65 shows an example of each input method.

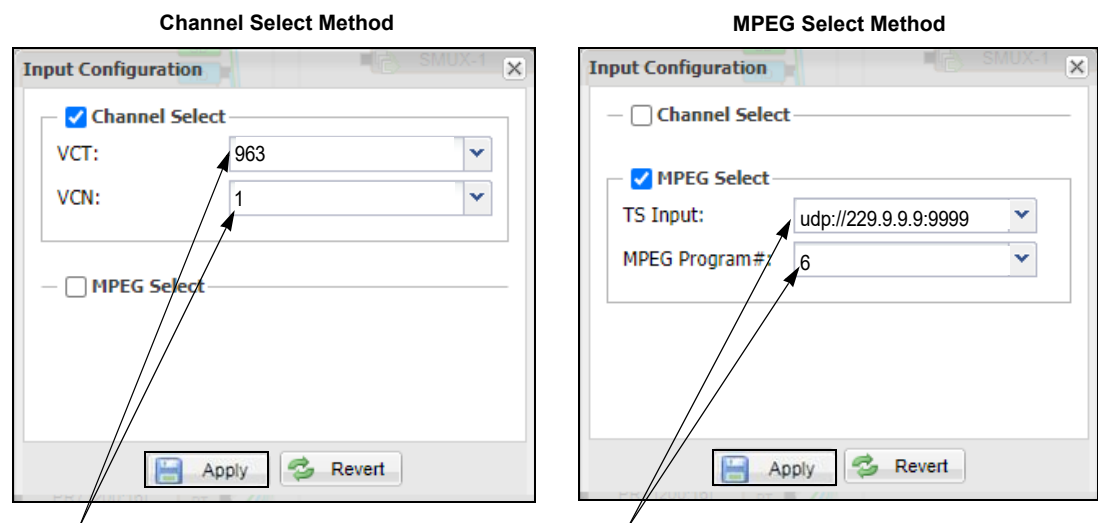

For Channel Select, set the VCT (Virtual Channel Table) and VCN (Virtual Channel Number) parameters as directed by the Programmer. The Programmer has the ability to override these settings.

For MPEG Select, set the TS Input parameter (IP address of the specified Ethernet port) and MPEG Program# parameter as directed by the Programmer. The Programmer cannot override these settings.

Figure 65: Input Configuration Dialog Box - Channel Select and MPEG Select (Example)

7. When all settings are complete, select the Apply button to activate the new settings.
8. If it is necessary to provide IP input to more than one processor, repeat steps 5 to 7 as necessary.
9. Look at the Transcoding Diagram and verify that a purple line was added between the IP Input port (icon at the bottom of the Input column) and the specified processor(s) (in the Channels column).

Figure 66 shows an example of the IP port connection to processors 5 through 12.

10. Select Save (the red button in the upper-right corner) to activate the new settings.

Note: The Programmer may configure the rest of the Transcoding Diagram. Please coordinate with the Programmer.

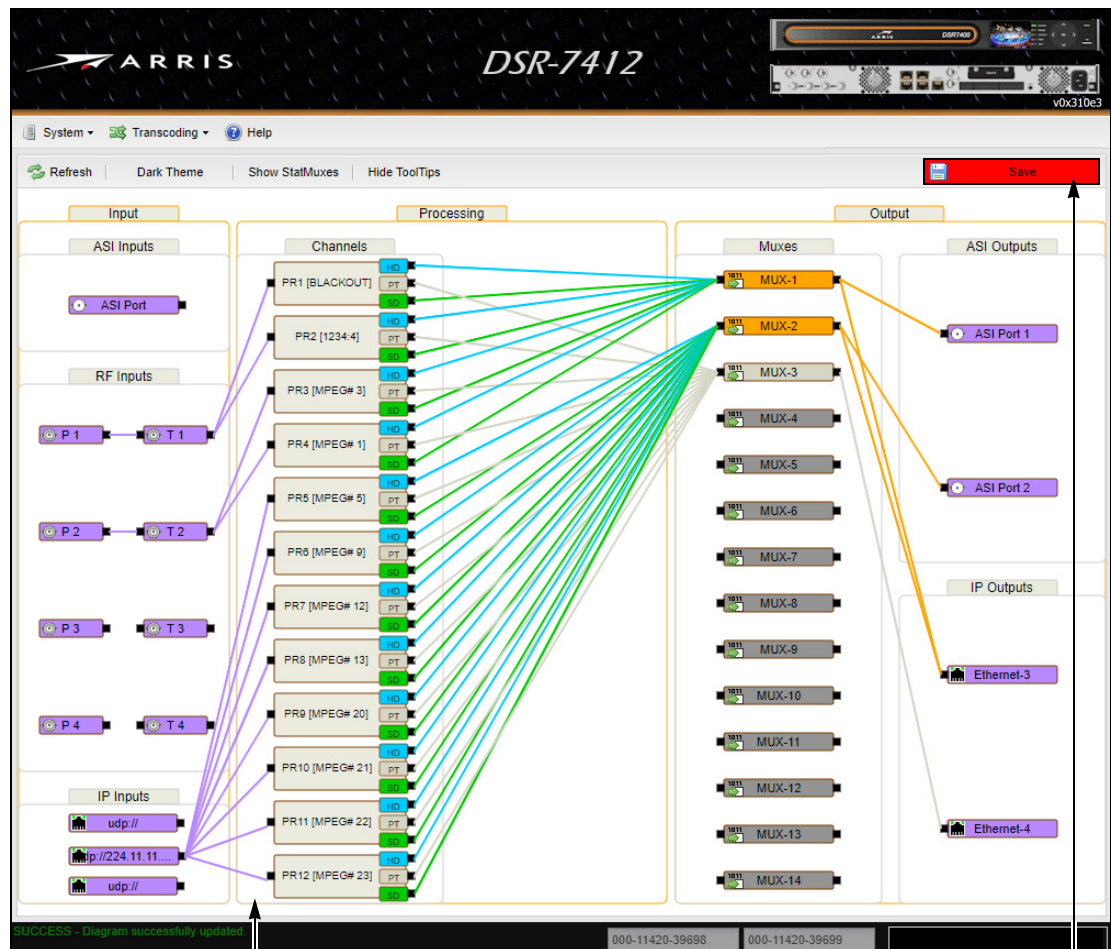

The purple lines in this example shows that processors 5 through 12 are configured to process IP input services.

Select the Save button to activate the changes.

Figure 66: Connecting an IP Input Port to a Processor (Example)

To configure UDP/IP output

This procedure must be performed at the downlink.

1. Verify that an IP output is connected to the desired IP output port on the back panel (either Ethernet-3 or Ethernet-4).
2. Log in to the Web GUI (described on page 63), go to the Transcoding Diagram, go to the Muxes column, and locate the Mux icon that will feed the IP output port.

Optional

3. If the Ethernet port already has one or more linked muxes (lines between a mux and the Ethernet port), it may be necessary to remove these links before a defining new link. To remove the unwanted links, right-click on the Ethernet port, choose Incoming Links and Remove All Incoming Links. Now, verify that the lines are removed from the Transcoding Diagram.
4. Use the mouse to click on the Mux icon, drag the mouse to the desired IP output port. When a green checkmark icon appears on the desired Ethernet icon, release the mouse (shown below).

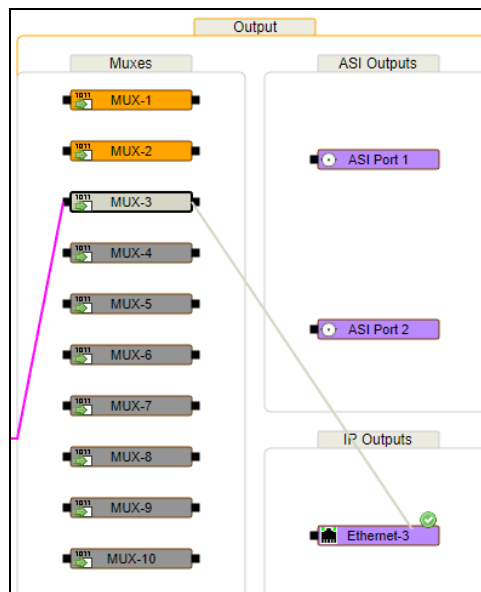

Figure 67: Viewing the Green Checkmark During Drag and Drop (Example)

5. When the IP Output dialog box appears (shown in Figure 68), use Table 15 to specify the desired settings, and select Apply.

The Programmer cannot override the parameters in this dialog box.

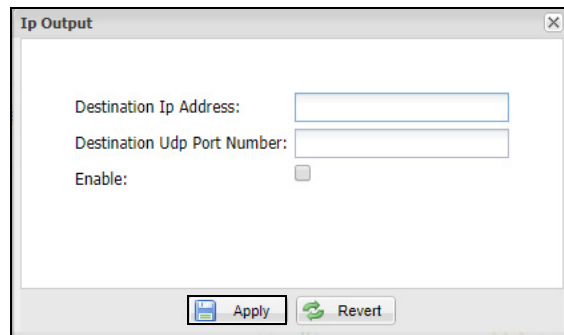

Figure 68: Configuring an IP Output Port's Destination Address Information (Example)

Table 15: IP Output Configuration Parameters

Parameter	Description
Destination IP Address	Use this field to enter the IP address for the outgoing transport stream.
Destination UDP Port Number	Use this field to enter the destination UDP port that is associated with the outgoing transport stream. Enter a value from 1 to 65535.
Enabled	Use this checkbox to enable/disable transport stream output on this Ethernet port.

6. Verify that a colored line appears between the Mux icon and the Ethernet icon. The color of the line will be either blue, gray, green, or gold. Color designations are described in Figure 56 on page 70.

Optional

7. If it is necessary to configure more links between muxes and Ethernet ports, repeat steps 1 to 7, as needed.
8. When all settings are complete, select the Save button (the red button in the upper-right corner) to activate the new settings.

Configuring CDN Streaming Services

Overview

This chapter describes how to configure the unit to receive programmer content delivered via IP networks as a Content Delivery Network (CDN) Streaming Services (shown in Figure 69).

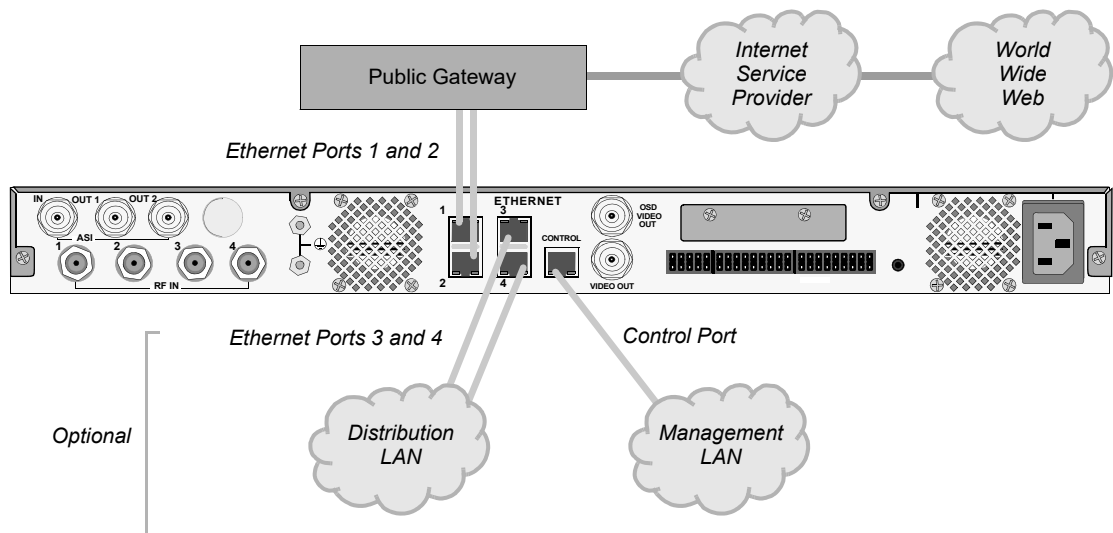

Figure 69: Typical CDN Network Connectivity

Use of the Ethernet ports 2, 3, 4, and Control ports are optional, depending on the affiliate's specific use case. If used, the operator should configure the desired IP address, subnet mask, and gateway, and make sure that the subnet is different for each of the Ethernet ports. The Ethernet 1 port is mandatory for this application and is used to access DigiCipher Streaming services, as well as auxiliary services required to establish and maintain network connectivity and proper IRD performance.

Network Requirements

The unit requires a minimum link rate of 100 Mbps (1 Gbps is also supported).

For important details about how to plan a DHCP implementation, see "DHCP Supported Parameters and Auto-Fill Capabilities" on page 65.

The following protocols must be permitted and supported by the network access device and ISP for proper IRD operation:

- ARP
- DHCP
- DNS
- HTTP
- HTTPS
- NTP - Access to NTP is mandatory. If no NTP server is specified, IRD will attempt to obtain time through time.nist.gov.

Procedures

To configure an IRD to receive DigiCipher Streaming services

1. Power on the unit, go to the back panel, and verify that Ethernet port 1 is connected to your site’s public gateway.
2. For each port that will be active, verify that the port illuminates either the amber LED or green LED. The following illustration describes the various states of the two LEDs.

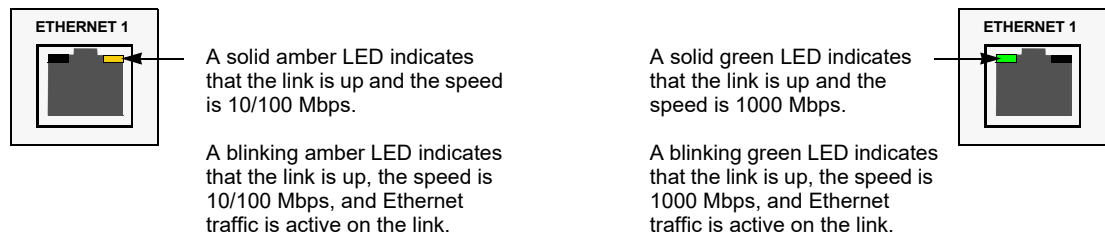

Note: Another way to verify that an Ethernet Port is active is to go to the Network screen and verify that the Line Rate field displays either 100 Mbps or 1000 Mbps. To do this, press the **Menu** button several times until the Main Menu appears, highlight **System**, press **OK**, highlight **Network**, and press **OK**.

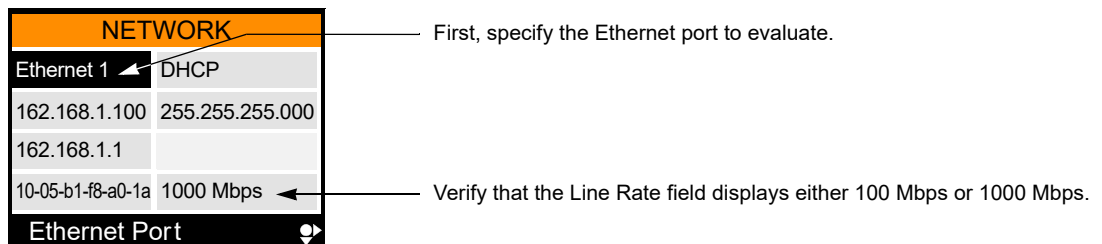

3. Press the **Menu** button several times until the Main Menu appears.

- Use the ▲ ▼ buttons to move to the **Quick Install** menu and press **OK** to enter the menu.
- When the Quick Install menu appears, use the ▲ ▼ buttons to move to the Input Port field (shown in red), press **OK** to enter the field, choose **IP**, and press **OK** to exit the field.

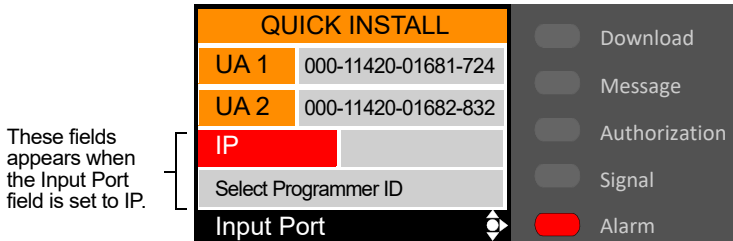

IMPORTANT: The IRD must be authorized to receive content that is being distributed by the Programmer.

- To specify the Programmer, use the arrow buttons to move to the Programmer ID field (shown in this example as 850T), press **OK** to enter the field, use the ▲ ▼ buttons to choose the desired Programmer ID, and press **OK** to exit the field.

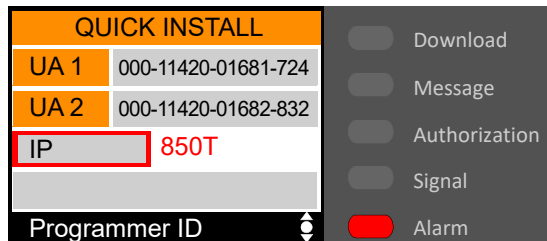

Note: If no Programmer IDs are selectable, go to the Network menu to see if Ethernet Port 1 is properly configured.

- Verify that the front-panel Signal LED is illuminated solid green and the IP Input Status field displays **Waiting for Config...**, as shown below.

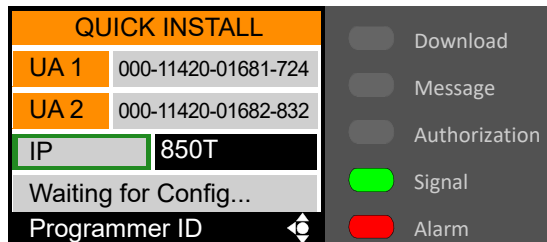

Note: If the Signal LED does not illuminate solid green, go to the Network screen to confirm proper configuration and operation of Ethernet 1 port.

At this point, the Programmer may perform an Instant Trip (immediate authorization message). However, if the IRD is already authorized by the Programmer, the IRD will eventually receive authorization and the appropriate configuration instructions.

- To verify that the IRD has received the configuration instructions, verify that the IP Input Status field displays **Configured**, as shown below.

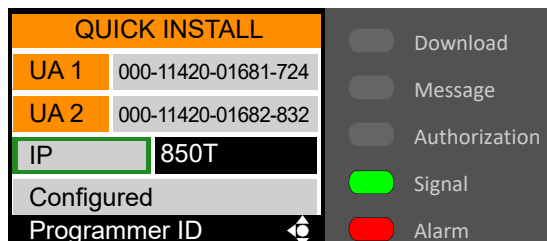

- Verify that the Authorization LED and Signal LED are illuminated solid green, as shown below.

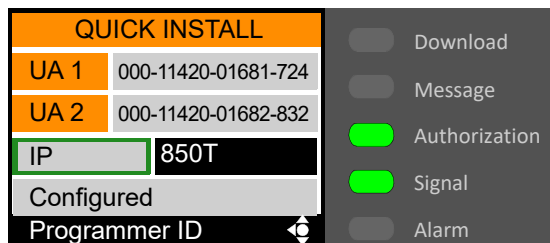

IMPORTANT: The Authorization and Signal LEDs may blink green for a short period of time before illuminating solid green. If the two LEDs do not display solid green, contact the Programmer to confirm assigned service and authorization.

Optional

- If the Authorization and Signal LEDs do not illuminate, it may be necessary to troubleshoot the issue. For details, see "Troubleshooting CDN Connectivity/Configuration Issues" (below).

Troubleshooting CDN Connectivity/Configuration Issues

If it is necessary to troubleshoot a connectivity or configuration problem with the CDN Streaming Service, observe the message in the IP Input Status field. Use the messages to track the status and troubleshoot any issues related to connectivity and configuration. Table 16 shows the status messages that may appear in the IP Input Status field during the connection process.

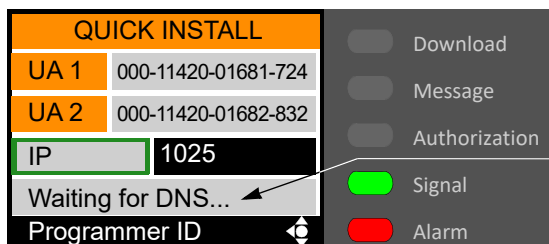

In this example, the IP Input Status field is displaying **Waiting for DNS...**

Table 16: Quick Install Status Messages

Quick Install Message	Description	Recommendation
Link Down	The Ethernet connections to Ethernet 1 port is not yet established.	Check the physical connection to Ethernet 1 Port. Verify that Ethernet 1 Port is receiving a signal from the desired network.
Conflicting Network Config	At least two IP ports are incorrectly configured to the same subnet.	Reconfigure the Ethernet ports so that all ports have a unique subnet.
No DNS	The DNS server(s) are not configured.	Verify that the DNS server(s) are specified by the DHCP or configure them manually.
Waiting for DNS...	The IRD is waiting for DNS resolution from the Beacon server(s).	Verify that the DNS is properly configured.
Waiting for Beacon...	The IRD is waiting to receive the list of programmers. This process requires a valid NTP configuration.	Verify that the IRD has Internet access and it is synchronized to an NTP server.
Connecting...	The IRD is in the process of retrieving information from a Beacon service.	Verify that the IRD has Internet access.
Select Programmer ID	This message appears when the Programmer ID field is not yet specified by the operator.	Use the front-panel arrow buttons (or Web GUI) to specify the desired Programmer ID. This specified Programmer ID must match the Programmer ID that is communicated to your site by the Programmer.

Table 16: Quick Install Status Messages (Continued)

Quick Install Message	Description	Recommendation
Connecting to Programmer...	The IRD is in the process of retrieving media from Programmer.	Verify that the IRD has Internet access.
Waiting for Config...	The IRD is waiting for unit-specific configuration data and the proper authorization from the Programmer.	Request a unit instant trip (immediate authorization message) or wait for authorization from the Programmer.
Configured	The IRD is properly configured.	No action is necessary. The Quick Install process is complete.

IMPORTANT: If the Operator Guide is not yet downloaded to a PC, perform "To download the operator guide to a personal computer" on page 30.

Viewing The Programmer's Service Information

The following procedure describes how to use the Web GUI to view the Programmer's Service Information and HLS configuration that is defined and controlled by the Programmer.

To view Service Information

1. Verify that Ethernet 1 port is connected to the public gateway, as shown in Figure 69 on page 87.
2. Verify that the personal computer (PC) is on the same IP subnet as the IRD's Control port.
3. Go to the PC, open the Internet Browser, enter IP address of the IRD's Control port, and press ENTER. ARRIS recommends using Chrome or Firefox.

For example, type **192.168.0.100** and press ENTER.
Do not type www or http.

4. When the Login window appears (as shown in Figure 70), leave the Password field blank and select the Login button.

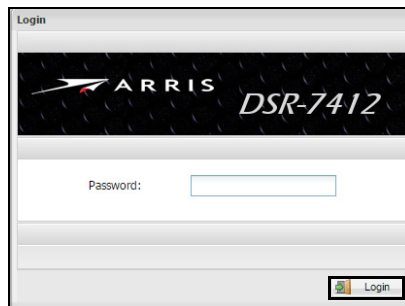
**Figure 70: Login Screen**

5. When the IRD's Web GUI appears, use the mouse to select the System pulldown menu and choose Service Information. An example screen is shown in Figure 71 on page 92 and the fields are described in Table 17 on page 92.

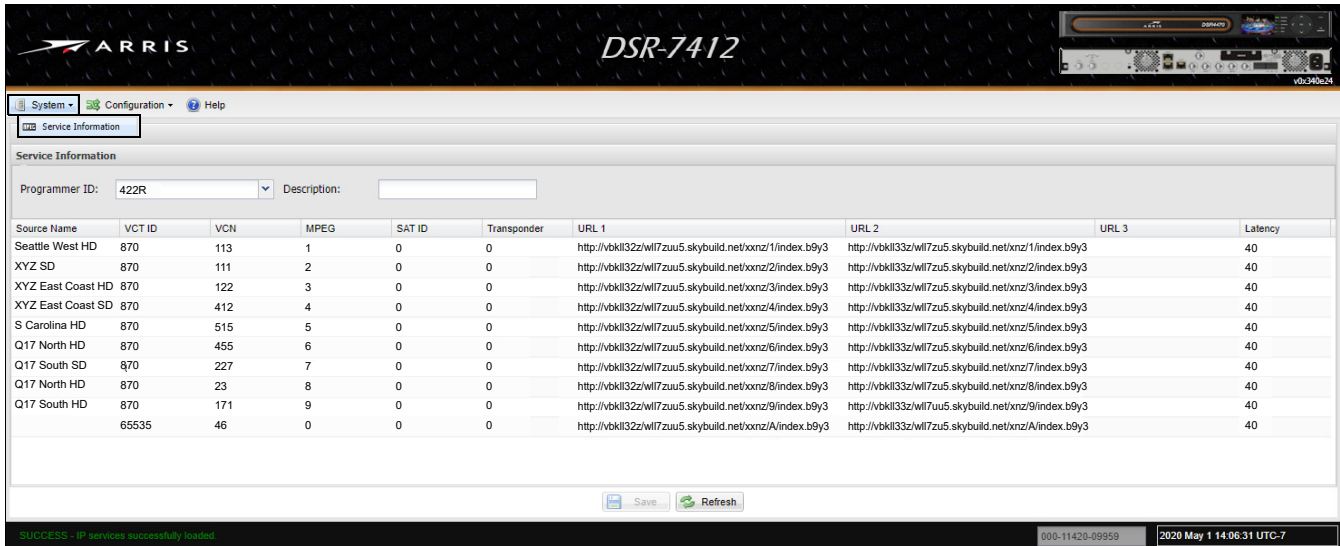

Figure 71: Service Information Screen (Example)

Table 17: Service Information Parameters

Parameter	Description
Programmer ID	The Programmer ID is a unique ID that is provided by programmer. This ID is used to uniquely identify the programmer’s content.
Description	The Description field is a verbal description that further describes the service. This field is an optional field and is provided by the programmer.
Source Name	A name (verbal description) that describes the content of this service.
VCT ID	The Virtual Channel Table (VCT) ID is required to select the desired program content and is used to group service numbers into a set.
VCN	The Virtual Channel Number (VCN) is the ID of the service within a VCT ID. This ID is required to select the desired program content.
MPEG	The MPEG service number of the service content. The MPEG service number is used for reference only.
SAT ID	The Satellite ID is an optional number that can be used to reference the original location of this content.
Transponder	The Transponder number is an optional number that can be used to reference the original location of this content.
URL 1	The primary Universal Resource Locator (URL) for this content. This URL is defined by the programmer.
URL 2	The secondary URL for this content. This URL is defined by the programmer.
URL 3	The tertiary URL for this content. This URL is defined by the programmer.
Latency	This field displays the overall end-to-end latency from uplink to downlink, in seconds.

- To display the IO diagram, use the mouse to select the Configuration pulldown menu and choose IO View.
- If it is necessary to view the HLS Configuration that was defined by the Programmer, go to the IP Inputs section, right-click on the Ethernet IP input icon, and choose Configure IP Input.

8. When the IP Input Configuration dialog box appears, verify that the HLS Config checkbox is checked. The dialog box is shown in Figure 72 and the fields are described in Table 18.

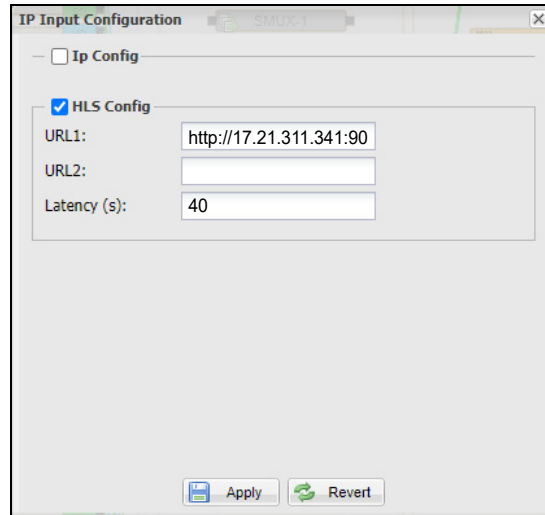

Figure 72: Viewing the Uplink's HLS Configuration Parameters (Example)

Table 18: HLS Configuration Parameters

Parameter	Description
HLS Config	This checkbox is checked if the receiver is configured to receive content from a Content Delivery Network (CDN).
URL1	This field displays the primary Universal Resource Locator (URL) associated with this content.
URL2	This field displays the secondary URL associated with this content.
Latency(s)	This read-only field displays the overall end-to-end delay from uplink to downlink, in seconds.

10

Downlink/L-Band Frequency Conversion Tables

A distributor or Programmer can provide the latest L-Band frequency plans at purchase time. Use the following formulas to perform calculations for both C-Band and Ku-Band transponders, or for installing a new satellite.

Formula for converting a C-Band Frequency to an L-Band Frequency	Example calculation if downlink frequency is 3,740 MHz
5,150 MHz <minus> Frequency Downlink (DL) <equals> Frequency (L-band)	5,150 MHz <u>-3,740 MHz</u> 1,410 MHz

Formula for converting a Ku-Band Frequency to an L-Band Frequency	Example calculation if downlink frequency is 12,019 MHz
Frequency Downlink (DL) <minus> 10,750 MHz <equals> Frequency (L-band)	12,019 MHz <u>-10,750 MHz</u> 1,269 MHz

PID Mapping

DSR-7400 HD units utilize a Program Number and Packet Identification (PID) mapping scheme for the unit's processors. Table 19 provides each model's default PID assignments in decimal and hexadecimal format. These Default PID Assignment values affect all output ports and are subject to change by the Programmer.

Table 19: DSR-7400 HD Series - Default PID Assignments

DSR-7400 HD Series Model			Processor	Type	Output MPEG Program	PMT PIDs		Video PIDs		Audio 1 PIDs		Audio 2 PIDs		Subtitle PIDs		DPI PIDs	
						Dec.	Hex	Dec.	Hex	Dec.	Hex	Dec.	Hex	Dec.	Hex	Dec.	Hex
7 4 0 3	7 4 0 6	7 4 0 1 2	1	PT	1	128	0080	144	0090	160	00A0	161	00A1	208	00D0	176	00B0
				SD	101	256	0100	272	0110	288	0120	289	0121	336	0150	304	0130
				HD	1001	384	0180	400	0190	416	01A0	417	01A1	464	01D0	432	01B0
			2	PT	2	640	0280	656	0290	672	02A0	673	02A1	720	02D0	688	02B0
				SD	102	768	0300	784	0310	800	0320	801	0321	848	0350	816	0330
				HD	1002	896	0380	912	0390	928	03A0	929	03A1	976	03D0	944	03B0
			3	PT	3	1152	0480	1168	0490	1184	04A0	1185	04A1	1232	04D0	1200	04B0
				SD	103	1280	0500	1296	0510	1312	0520	1313	0521	1360	0550	1328	0530
				HD	1003	1408	0580	1424	0590	1440	05A0	1441	05A1	1488	05D0	1456	05B0
			4	PT	4	1664	0680	1680	0690	1696	06A0	1697	06A1	1744	06D0	1712	06B0
				SD	104	1792	0700	1808	0710	1824	0720	1825	0721	1872	0750	1840	0730
				HD	1004	1920	0780	1936	0790	1952	07A0	1953	07A1	2000	07D0	1968	07B0
			5	PT	5	2176	0880	2192	0890	2208	08A0	2209	08A1	2256	08D0	2224	08B0
				SD	105	2304	0900	2320	0910	2336	0920	2337	0921	2384	0950	2352	0930
				HD	1005	2432	0980	2448	0990	2464	09A0	2465	09A1	2512	09D0	2480	09B0
			6	PT	6	2688	0A80	2704	0A90	2720	0AA0	2721	0AA1	2768	0AD0	2736	0AB0
				SD	106	2816	0B00	2832	0B10	2848	0B20	2849	0B21	2896	0B50	2864	0B30
				HD	1006	2944	0B80	2960	0B90	2976	0BA0	2977	0BA1	3024	0BD0	2992	0BB0
			7	PT	7	3200	0C80	3216	0C90	3232	0CA0	3233	0CA1	3280	0CD0	3248	0CB0
				SD	107	3328	0D00	3344	0D10	3360	0D20	3361	0D21	3408	0D50	3376	0D30
				HD	1007	3456	0D80	3472	0D90	3488	0DA0	3489	0DA1	3536	0DD0	3504	0DB0
			8	PT	8	3712	0E80	3728	0E90	3744	0EA0	3745	0EA1	3792	0ED0	3760	0EB0
				SD	108	3840	0F00	3856	0F10	3872	0F20	3873	0F21	3920	0F50	3888	0F30
				HD	1008	3968	0F80	3984	0F90	4000	0FA0	4001	0FA1	4048	0FD0	4016	0FB0
			9	PT	9	4224	1080	4240	1090	4256	10A0	4257	10A1	4304	10D0	4272	10B0
				SD	109	4352	1100	4368	1110	4384	1120	4385	1121	4432	1150	4400	1130
				HD	1009	4480	1180	4496	1190	4512	11A0	4513	11A1	4560	11D0	4528	11B0
			10	PT	10	4736	1280	4752	1290	4768	12A0	4769	12A1	4816	12D0	4784	12B0
				SD	110	4864	1300	4880	1310	4896	1320	4897	1321	4944	1350	4912	1330
				HD	1010	4992	1380	5008	1390	5024	13A0	5025	13A1	5072	13D0	5040	13B0
			11	PT	11	5248	1480	5264	1490	5280	14A0	5281	14A1	5328	14D0	5296	14B0
				SD	111	5376	1500	5392	1510	5408	1520	5409	1521	5456	1550	5424	1530
				HD	1011	5504	1580	5520	1590	5536	15A0	5537	15A1	5584	15D0	5552	15B0
			12	PT	12	5760	1680	5776	1690	5792	16A0	5793	16A1	5840	16D0	5808	16B0
				SD	112	5888	1700	5904	1710	5920	1720	5921	1721	5968	1750	5936	1730
				HD	1012	6016	1780	6032	1790	6048	17A0	6049	17A1	6096	17D0	6064	17B0

PT: Pass Thru SD: Standard Definition HD: High Definition

Upgrading Firmware Using the Web GUI

Introduction

Normally, firmware upgrades are performed automatically by the Programmer. This uplink process affects a specific group of decoders, all at one time. Occasionally, it may be necessary to perform a manual firmware upgrade on an individual unit. This chapter describes the Web GUI's System Upgrade screen and how to perform a manual firmware upgrade on an individual unit.

IMPORTANT: *If it is necessary to upgrade the decoder's firmware using a personal computer (PC), do not attempt this on your own. Contact ARRIS Product Support (described on page 18) in order to receive a firmware file and any specific details that are not described in this chapter.*

When the decoder is initially powered on, the Web GUI System Upgrade screen shows one firmware file version number. This is the factory-loaded firmware file image and it has an Active designation of `true`.

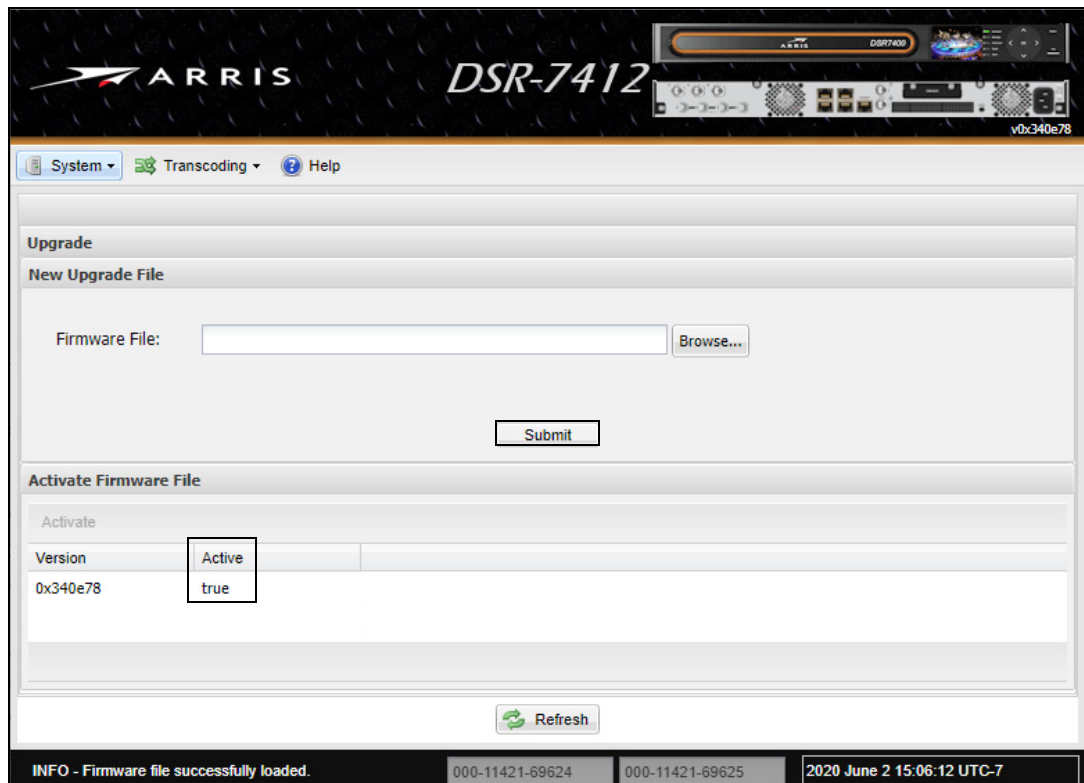

The illustration on page 99 shows one firmware file. The active file always has the designation of **true**. If a second firmware file is loaded, it is listed below the first line and has a designation of **false**. The Activate Firmware File section will never display more than two firmware files at a time.

If you receive a new firmware file from an ARRIS representative, you will be directed to put the file on a personal computer (on the same subnet as the Control port) and then browse to the file location and submit the file. This will download the file to the decoder. When the download is complete, the Upgrade File section shows a second version number with a designation of **false**.

If two files are listed and the user loads yet another firmware file, the inactive file (the file on the bottom line with the designation of **false**) will be deleted from the decoder and therefore, removed from the list. When the download is complete, the newly-loaded firmware file is added to the list with a designation of **false**.

Selecting/Highlighting the firmware file (with designation **false**) and clicking the Activate button will automatically:

- Save the current database and attach it to the newly-activated firmware. This is referring to the database that contains all site-specific data that was entered from the decoder's front panel (or Web GUI) and from the Programmer (BNC Client GUI).
- Reverse the true/false designations of the two firmware versions.
- Reboot the decoder with the newly-activated file.

Verify PC Minimum Requirements

Before performing an upgrade, use the following table to verify that the personal computer meets the minimum requirements.

Characteristic	Personal Computer Minimum Requirement
Processor	2.3 GHz Intel Core2 Dual-Core
Ethernet Connectivity	One 10/100/1000 (Gigabit) Base-T Ethernet Card
Hard Disk	One 250 GB
Memory	4 GB RAM
Viewing Software	Adobe PDF Reader or equivalent
Operating System and	Windows 7 (and higher) with either Chrome 35 (and higher) or Firefox 26 (and higher).
Internet Browser	Linux - Any version that will run either Chrome 35 (and higher) or Firefox 26 (and higher).

Performing an Upgrade

Use the following procedure to upgrade firmware on a single unit.

To upgrade the decoder's firmware version

1. Verify that you have received a firmware file from an ARRIS representative and you have saved it to your personal computer.
2. Verify that your personal computer is on the same subnet as the decoder's Control port.
3. Open an Internet browser window and type the Control port's IP address in the Address box. ARRIS recommends using Chrome or Firefox.

For example, type **192.168.0.100** and press ENTER.
Do not type www or http.

- When the Login window appears, as shown below, leave the Password field blank and select the Login button located at the bottom-right corner.

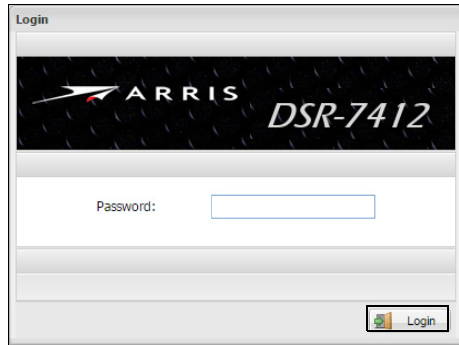

- When the main window appears, select the System pulldown menu and choose Upgrade. For a detailed description of each parameter, see the table on page 102.

The loaded file name appears here.

This example shows two firmware versions.

Your screen may show only one firmware file.

This example shows that version 0x340e78 is loaded and active. Version 0x340e79 is loaded, but not active.

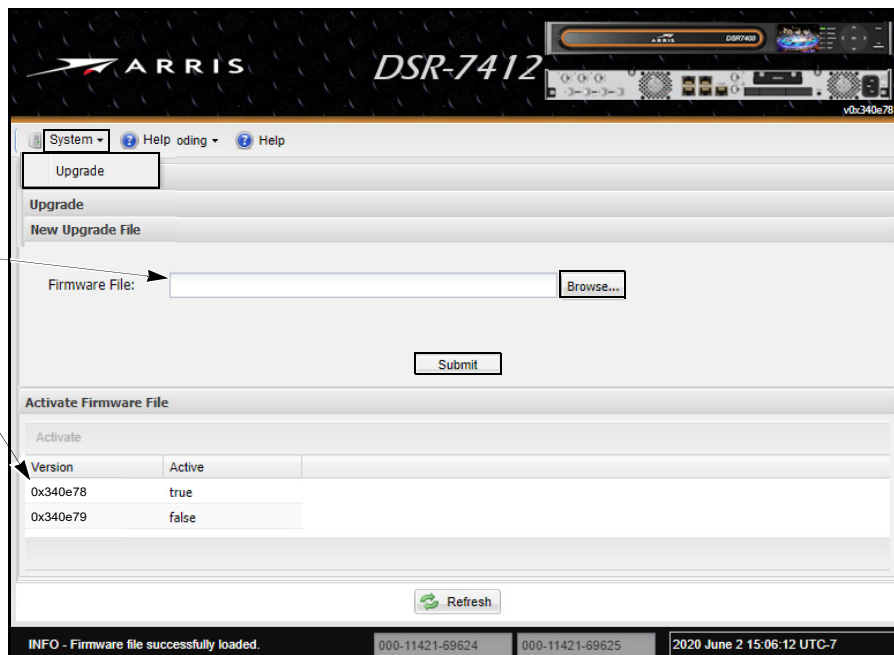

- Select the Browse button. When the dialog box appears, navigate to the directory containing the firmware file, highlight the firmware file, and select Open.
- When the following message appears, select OK.

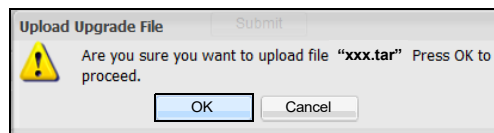

- Verify that the Firmware File field is displaying the proper file version.
- Select the Submit button to copy the designated file (shown in the Firmware File field) to the decoder. This will also add the firmware file to the bottom line of the Activate Firmware File Table.

CAUTION: The following three steps will cause the decoder to automatically reboot, so use it carefully.

10. To upgrade to the new firmware version, use the mouse to highlight the file that has the **false** designation, and select the Activate button.
11. When the following message appears, select Yes.

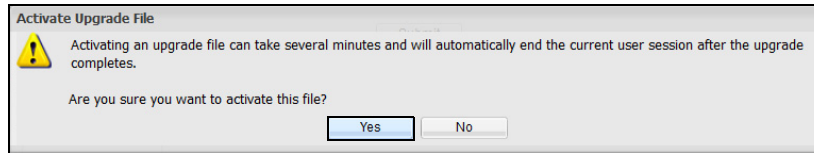

IMPORTANT: The download/upgrade process may take several minutes. Do not attempt to do anything with the GUI until the System Upgrade / System Upgrade Complete message appears.

12. When the System Upgrade / System Upgrade Complete message appears (shown below), select OK.

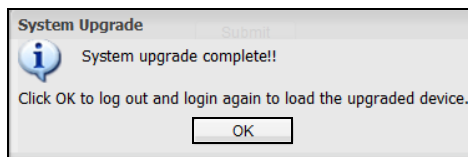

13. Verify that the proper version has the **true** designation and the other version has the **false** designation.
14. When you are satisfied that the upgrade is complete, select the Close button (**X**) in the upper-right corner of the browser window.

Parameter	Description
New Upgrade File Section	
Firmware File (read-only field)	This field displays the filename to be copied from the personal computer to the decoder. See the Browse button (described below) for more details.
Browse (button)	Select this button to display a dialog box. Then, navigate to the appropriate directory on the personal computer's hard drive, highlight the desired firmware file, and select Open. This will cause the Firmware File field (described above) to display the filename.
Submit (button)	After using the Browse button (described above) to locate and highlight the file, select this button to copy the designated file (shown in the Firmware File field) to the decoder. This will also add the firmware file to the bottom line of the Activate Firmware File Table (described below).
Activate (button)	Use this button to activate the file that has the false designation. To do this, first use the mouse to highlight the firmware file with the false designation. Then, select the Activate button. <i>Note: Two files must be listed in order to use the Activate button. If only one file is listed, the Activate button is grayed out and inoperable.</i>
Activate Firmware File Table	
Version	This read-only field displays the firmware version number.
Active	This read-only field displays the status of the firmware file.
true	The firmware file is currently active. The associated database is saved with the site-specific changes that were entered at the decoder and at the Programmer's BNC Client GUI.
false	The firmware file is loaded, but not active. The associated database is not being updated.

Managing SNMP Trap Receivers

Simple Network Management Protocol (SNMP) Traps are generated as defined within the customer's Management Information Base (MIB) file that is provided by ARRIS Product Support. The unit supports up to four SNMP Trap receivers for remote status monitoring. The following table describes each field. Use the procedure on page 104 to configure SNMP Trap Receivers.

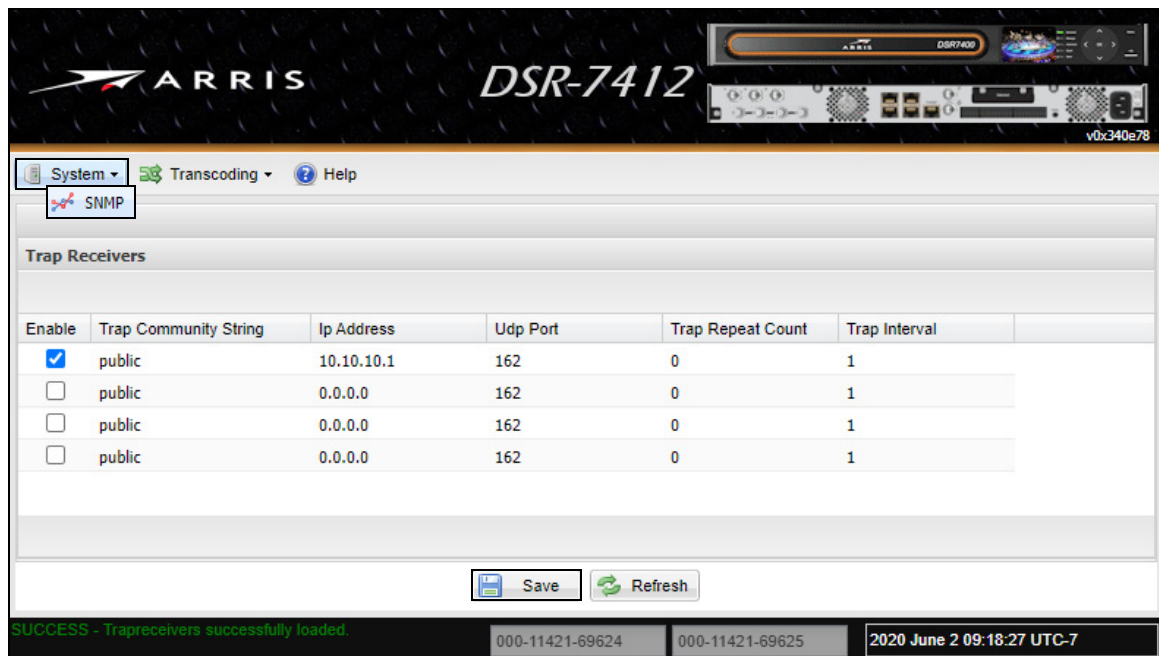

Parameter	Description
Enable (Checkbox)	If it is necessary to route traps to the customer's trap receiver (specified below as the IP Address), click on this checkbox to display a checkmark. If a trap receiver is not being used, do not display a checkmark.
Trap Community String	Type any arbitrary name. This name will be included in trap messages sent to the customer's trap receiver.
IP Address	Use this field to specify an IP address of an intended trap receiver.
Udp Port	This is the UDP port number of SNMP to receive traps. This read-only value is always 162 and cannot be changed.
Trap Repeat Count	The number of times each trap message is repeated. Enter a value from 0 to 7.
Trap Interval	The time interval between each repeated trap message. Enter a value from 1 to 50. 1 designate a interval of 0.1 second and 50 designates an interval of 5 seconds.

Currently, these three parameters cannot be changed or saved.

To configure a trap

1. Open an Internet browser window and type the Control port's IP address in the Address box. ARRIS recommends using Chrome or Firefox.

For example, type **192.168.0.100** and press ENTER.
Do not type www or http.

2. When the Login window appears, as shown below, leave the Password field blank and select the Login button that is located at the bottom-right corner.

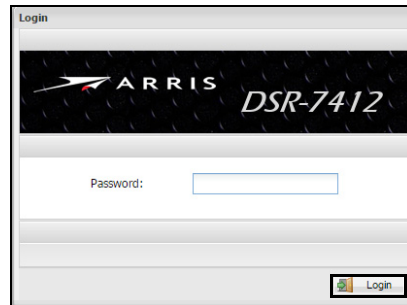

3. When the main window appears, select the System pulldown menu and choose SNMP.
4. When the Trap Receivers window appears, use the mouse to check the Enable checkbox.
5. Edit the Trap Community String and the IP Address.
6. When all changes are complete, select Save.

DSR-7400 HD Series Specifications

RF	
Input Frequency Range	950 to 2150 MHz
Input RF Level	-25 to -65 dBm
RF Port Impedance	75 Ω
LNB Power	18 V, 450 mA Maximum

Transmission Standard		
8PSK-TC	FEC Rates	2/3 (1.92), 3/4 (2.05), 3/4 (2.11), 5/6 (2.30), 8/9 (2.40)
DCII	Symbol Rates QPSK Code Rate	19.51, 29.27 Msps 3/4
DVB-S2	Symbol Rates 8PSK Code Rates 16APSK Code Rates	3 to 35 Msps 3/5, 2/3, 3/4, 5/6, 8/9, 9/10 2/3, 3/4, 4/5, 5/6, 8/9, 9/10
DVB-S2x	Symbol Rates 8PSK Code Rates 16APSK Code Rates	3 to 35 Msps 3/5, 2/3, 3/4, 5/6, 8/9, 9/10 26/45, 3/5, 28/45, 23/36, 25/36, 13/18, 7/9, 77/90

Video	
Video Level	1.0 V p-p \pm 10%
Video Output Impedance	75 Ω
Chrominance-Luminance Delay Line	\pm 26 nsec
Differential Gain	4%
Differential Phase	1.5 Degrees

Audio	
Two Stereo Pairs	Four Channels
Peak Audio Level	+20 dBm Analog (0 dBFS)
Frequency Response	± 1 dB, 20 Hz to 20 KHz
Total Harmonic Distortion	0.25% at 1 KHz

Connectors	
RF In	F-Type Connector (Qty 4)
ASI In	BNC Connector (Qty 1)
ASI Out	BNC Connector (Qty 2)
Gigabit Ethernet	RJ-45 Connector (Qty 5)
Video Out	BNC Connector (Qty 1)
OSD Video Out	BNC Connector (Qty 1)
Audio Out	Terminal Block
Alarm Relay	Terminal Block
Cue Tone	Terminal Block
Contact Closure Relay	Terminal Block

Electrical			
Model	Amps	VAC	Hertz
DSR-7403	1.5 to 0.7 A	100 to 240 VAC	50/60 Hz
DSR-7406	2.0 to 0.9 A		
DSR-7412	3.0 to 1.3 A		

Mechanical				
Model	Unit Only		Packaged Finished Good	
	Dimensions	Weight	Dimensions	Weight
DSR-7403	24.90" D	17.6 lbs. (8 kg)	32.0" D	23.8 lbs. (10.8 kg)
DSR-7406	18.90" W	18.9 lbs. (8.6 kg)	22.0" W	24.6 lbs. (11.2 kg)
DSR-7412	1.75" H	20.9 lbs. (9.5 kg)	6.7" H	27.1 lbs. (12.3 kg)

SAVE THESE INSTRUCTIONS	
	<p>When you see this symbol on an ARRIS product, do not dispose of the product with residential or commercial waste.</p> <p>Recycling your ARRIS Equipment</p> <p>Please do not dispose of this product with your residential or commercial waste. Some countries or regions, such as the European Union, have set up systems to collect and recycle electrical and electronic waste items. Contact your local authorities for information about practices established for your region. If collection systems are not available, call ARRIS Customer Service for assistance.</p>

This product conforms to RoHS 2011/ 65/EU & WEEE 2012/19/EU directives.

DSR-7412 Only



この装置は、クラスA機器です。この装置を住宅環境で使用すると電波妨害を引き起こすことがあります。この場合には使用者が適切な対策を講ずるよう要求されることがあります。 **VCCI – A**

This is a Class A equipment. Operation of this equipment in a residential environment could cause radio interference. In such a case, the user may be required to take corrective actions. **VCCI – A**



DECLARATION OF CONFORMITY

Issue Date: June 22, 2016
 Issued By: ARRIS International plc
 6450 Sequence Drive
 San Diego, CA 92121, USA

	<p>The object of the declaration described below is in conformity with the relevant Union harmonization legislation:</p> <p>EMC Directive 2014/30/EU, Low Voltage Directive 2014/35/EU, RoHS Directive 2011/65/EU, WEEE Directive 2012/19/EU and carries the CE-marking. Compliance is dependent upon the equipment being properly installed and maintained, and when it is used for the purposes for which it is intended.</p>
---	--

Type (Name)	Object of Declaration
Commercial Integrated Transcoder/Receiver	DSR-7400 Series

SAFETY

2014/35/EU-LVD Directive
 EN 60950-1:2006+A11:2009+A1:2010+A12:2011+A2:2013
 IEC 60950-1:2005/AM2009

RoHs/WEEE

2011/65/EU-RoHS Directive
 EN 50581:2012
2012/19/EU – WEEE Directive

RADIO/EMC

2014/30/EU EMC Directive
 EN55022: 2010 + AC-2011, Class A
 EN55024: 2010
 EN 61000-3-2: 2014
 EN 61000-3-3: 2013
 IEC 61000-4-2: 2009
 IEC 61000-4-3: 2006 + A1:2008 + A2:2010
 IEC 61000-4-4: 2012
 IEC 61000-4-5: 2014
 IEC 61000-4-6: 2014
 IEC 61000-4-8: 2010
 IEC 61000-4-11: 2004

Authority of Issuer:

Position	Name	Signature	Date
Director of Engineering	Todd Kassman		6/28/2016



Corporate Headquarters
CommScope · Hickory · North Carolina · 28602 · USA
T: 1-828-324-2200
www.commscope.com

365-095-33219 x.6 7/27/20